

HILTI

Hilti X-BT Threaded Fastener Specification

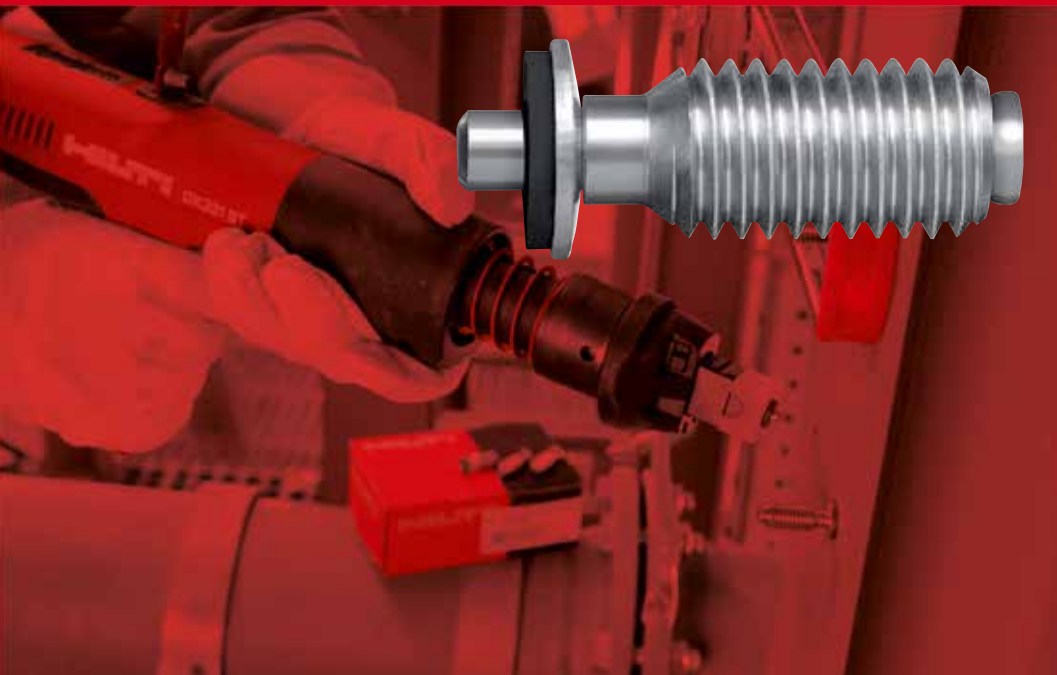

June 2015

| | |
|---|----------------|
| 1. Introduction | page 4 |
| 1.1 Definitions and general terminology | 4 |
| 1.2 The X-BT system | 4 |
| 1.3 X-BT system features and benefits – simplified fastening to steel | 5 |
| 1.4 Installation method and anchoring mechanism | 6 |
| 1.5 X-BT and X-BT-ER applications | 6 |
| 2. Applications | page 7 |
| 2.1 Grating fastening system | 7 |
| 2.2 X-BT and MQ installation channel system | 9 |
| 2.3 Fastening instrumentation, junction boxes and lighting | 10 |
| 2.4 Fastening cable/conduit connectors | 11 |
| 2.5 Fastening cable tray supports | 11 |
| 2.6 X-BT for fastening and connecting earthing devices | 12 |
| 2.6.1 Functional bonding and terminal connection in a circuit | 12 |
| 2.6.2 Protective bonding circuit | 12-13 |
| 2.6.3 Lightning protection | 13 |
| 3. Technical data | page 14 |
| 3.1 Product data | 14 |
| 3.1.1 Material specifications | 14 |
| 3.1.2 Fastening tool | 14 |
| 3.1.3 Approvals | 15 |
| 3.2 Load data | 16 |
| 3.2.1 Loads - steel base material | 16 |
| 3.2.2 Loads - cast iron base material | 16-17 |
| 3.3 Application requirements and limits | 17 |
| 3.3.1 Thickness of fastened material - X-BT | 17 |
| 3.3.2 Thickness of cable lug - X-BT-ER | 17 |
| 3.3.3 Spacing and edge distance | 17 |
| 3.3.4 Application limit/thickness of base material | 17 |
| 3.3.5 Fastener selection | 18 |
| 3.3.6 Cartridge selection and tool energy setting | 18 |
| 3.3.7 Installation details - X-BT | 18 |
| 3.3.8 Installation for electrical connections - X-BT-ER | 19 |
| 3.3.9 Fastening quality assurance | 19 |
| 4. Method statement | page 20 |
| 4.1 Instructions for use - X-BT | 20 |
| 4.2 Instructions for use - X-BT-ER M10/W10 | 20 |
| 4.3 Instructions for use - X-BT-ER M6/W6/M8 | 21 |

| | |
|---|----------------|
| 5. Performance (technical reports) | page 22 |
| 5.1 Nomenclature and symbols / design concepts | 22-23 |
| 5.2 Static capacity of the X-BT threaded stud | 24 |
| 5.2.1 Tensile load deformation behavior of the X-BT threaded stud fastenings | 24 |
| 5.2.2 Pullout strength of X-BT threaded stud fastenings | 25 |
| 5.2.3 Shear strength of X-BT threaded stud fastenings | 26 |
| 5.2.4 Effect of edge distance/spacing on pull-out strength of X-BT fastenings | 27-28 |
| 5.2.5 Holding mechanisms X-BT threaded stud fastenings | 29 |
| 5.3 Corrosion resistance | 30 |
| 5.3.1 X-BT threaded stud fastening corrosion data | 30-31 |
| 5.3.2 Contact corrosion – X-BT stainless steel stud in carbon steel | 32 |
| 5.3.3 Corrosion data from field tests at Helgoland island (North Sea) | 33 |
| 5.4 Effect of X-BT threaded stud fastenings on steel base material | 34 |
| 5.4.1 Fatigue classification in compliance with Eurocode 3 | 35 |
| 5.4.2 Approved fatigue categories by GL and DNV | 36-37 |
| 5.5 Technical data for X-BT fastenings made to cast iron with spheroidal graphite | 38 |
| 5.5.1 Cast iron specification | 38 |
| 5.5.2 Grounding and bonding restrictions | 38 |
| 5.5.3 Performance review | 39-40 |
| 5.6 Vibration effects on X-BT threaded stud fastenings | 41 |
| 5.7 Temperature resistance of X-BT threaded stud fastenings | 42-43 |
| 5.8 X-BT-ER stainless steel threaded studs electrical performances | 44 |
| 5.8.1 Permanent current | 44-45 |
| 5.8.2 Short circuit current | 46-47 |
| 5.8.3 Lightning current | 48 |
| 5.9 X-BT in stainless steel base material | 49 |
| 5.10 X-BT under shock loading | 50 |
| 5.11 X-BT stud in steel with a thickness of less than 8 mm | 51 |
| 5.11.1 Pull-out capacity in thin steel | 51 |
| 5.11.2 Shear load capacity in thin steel | 51-52 |
| 5.11.3 X-BT electrical conductivity in thin steel | 52 |
| 5.12 Chemical resistance of SN 12 sealing washer | 53 |
| 5.13 Material safety data sheet of SN 12 sealing washer | 54-60 |
| 6. Approvals | page 62 |
| 6.1 American Bureau of Shipping (ABS) | 62-64 |
| 6.2 Lloyd's Register | 65-67 |
| 6.3 Germanischer Lloyd (GL) | 68-70 |
| 6.4 Det Norske Veritas (DNV) | 71-73 |
| 6.5 Russian Maritime Register | 74-75 |
| 6.6 Bureau Veritas (BV) | 76-78 |
| 6.5 ICC Evaluation Services (ICC-ES) | 80-85 |
| 7. Customer testimonials | page 86 |

1. Introduction

1.1 Definitions and general terminology

Hilti direct fastening technology is a technique in which especially hardened nails or studs are driven into steel, concrete or masonry by a piston-type tool. Materials suitable for fastening by this method are steel, wood, insulation and some kinds of plastic. Fastener driving power is generated by a power load (a cartridge containing combustible propellant powder, also known as a “booster”), combustible gas or compressed air. During the driving process, base material is displaced and not removed. In Hilti terminology, DX stands for “powder-actuated” systems.

1.2 The X-BT system

X-BT stainless steel threaded stud

X-BT M10-24-6 SN12-R
X-BT W10-24-6 SN12-R

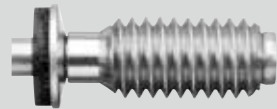

X-BT M8-15-6 SN12-R



X-BT M6-24-6 SN12-R
X-BT W6-24-6 SN12-R



X-BT-ER stainless steel threaded stud for electrical connections

X-BT-ER M10/3 SN 4
X-BT-ER W10/3 SN 4

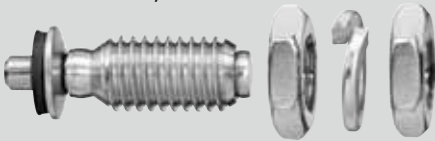

X-BT-ER M8/7 SN 4

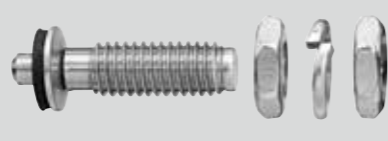

X-BT-ER M6/7 SN 4
X-BT-ER W6/7 SN 4

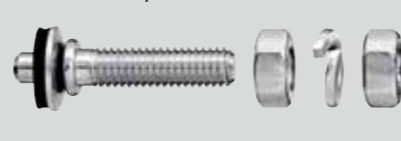

Tools and components

DX 351 BT



X-351-BT FG M1024



X-351-BT P 1024



X-351-BT FG W1024



DX 351 BTG



X-351-BT FG G



X-351-BT P G



Only for fastening X-BT M8-15-6 SN12-R

Cartridges and drill bits

6.8/11 M brown



TX-BT 4/7-80



TX-BT 4/7-110



TX-BT 4/7-150



1.3 X-BT system features and benefits – simplified fastening to steel

No rework.

Stud welding or through-bolting, for example, may require reworking of the protective surface coating. With X-BT, the stud is set into a small pre-drilled hole and the drill entry point is then completely sealed by the stud washer during setting.

Simple and fast.

A minimal amount of training is all that's required for a user to be able to drive up to 100 studs per hour.

High corrosion resistance.

X-BT studs are made of high grade A4 (316 SS equivalent) stainless steel, making them the right choice for almost every corrosive environments.

High loading and pull-out values.

X-BT delivers performance comparable to methods such as stud welding.

Fasten to all steel shapes.

Unlike clamps, which are limited by the configuration of the base steel, the X-BT is ideal for use on hollow sections, channel sections, wide flanges and angles.

Fasten to all steel grades.

In addition to fastening to standard construction steel, the X-BT can also be used to fasten to high strength and thick steel.

Portable.

The fastening tool's self-contained energy source eliminates the need for electrical cords and heavy welding equipment.

No through-penetration.

The special process of drilling and driving results in secure fastening of the stud without through-penetration of the base material.



Rework



Corrosion



Loosening



Through-penetration

1.4 Installation method and anchoring mechanism

The blunt-tipped fastener X-BT with a shank diameter of 4.5 mm is driven in a pre-drilled 4.0 mm diameter hole. This leads to displacement of the base material. Part of the base steel is punched down into the pre-drilled hole, generating high temperatures and causing friction welding. Due to elasticity of the base steel, additional clamping effects are also superposed. Displaced base material can be clearly seen in the photograph. Base material adhering to the fastener shank indicates a welding effect.

(For more details regarding installation, please refer to **Part 4 – Method statement**)

1.5 X-BT and X-BT-ER applications

Metal / fiberglass grating to steel for upstream and high corrosion environment



X-BT M8 +
X-FCM-R

Fastening Hilti MQ installation channel system, metal brackets, clips, metal tracks, etc. to steel



X-BT M10
X-BT W10
X-BT M8
X-BT M6
X-BT W6

Mechanical and electrical for petro chemical industry, shipbuilding, etc.



X-BT M10
X-BT W10
X-BT M6
X-BT W6

Functional and protective bonding and lightning protection



X-BT-ER M10
X-BT-ER W10
X-BT-ER M8
X-BT-ER M6
X-BT-ER W6

2. Applications

2.1 Grating fastening system

(X-BT M8-15-6 SN12-R and X-FCM-R)

An all stainless steel fastening system designed for attaching metal and fiberglass grating to coated steel and/or high-strength steel

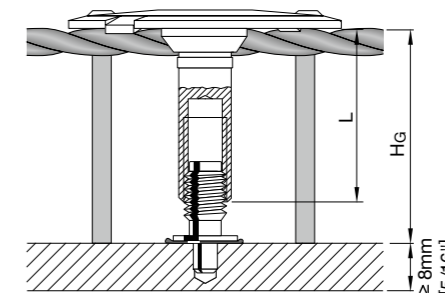
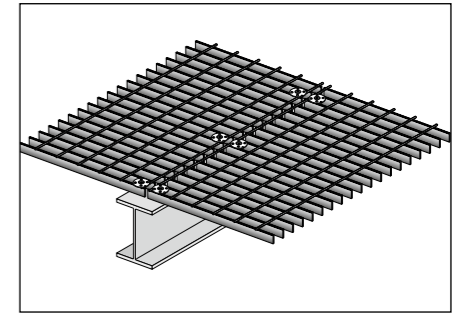

X-FCM-R grating disc

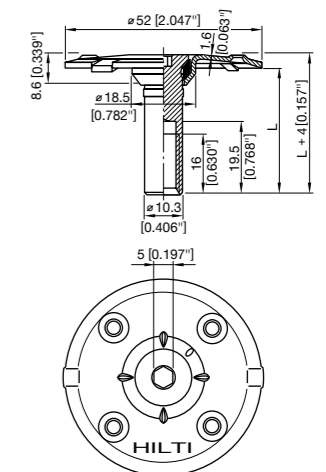

Important: The X-FCM-R system is not designed or intended to resist shear loads.

X-SEA-R 30 M8 extension adaptor

For use with X-FCM-R grating fasteners for fastening of grating with a height in excess of 50 mm/1.97 in.

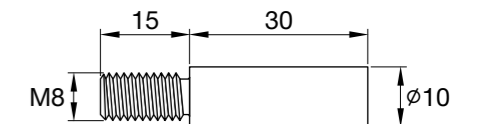
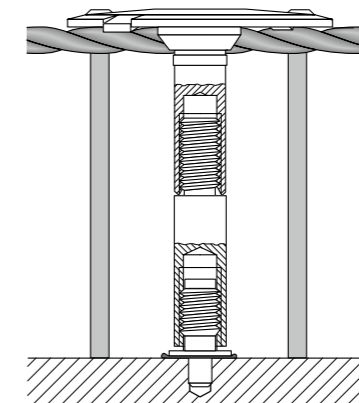

Fastener selection

| Designation | L (mm/in.) | Grating height, HG, range (mm/in.) | Grating height with X-SEA-R 30 M8 |
|----------------|------------|------------------------------------|-----------------------------------|
| X-FCM-R 25/30 | 23/0.91 | 25-30/0.98-1.18 | 55-60/2.16-2.36 |
| X-FCM-R 1"-1¼" | 27/1.06 | 29-34/1.14-1.34 | 59-64/2.32-2.52 |
| X-FCM-R 35/40 | 33/1.30 | 35-40/1.38-1.57 | 65-70/2.56-2.75 |
| X-FCM-R 45/50 | 43/1.69 | 45-50/1.77-1.97 | 75-80/2.91-3.15 |

Installation instructions

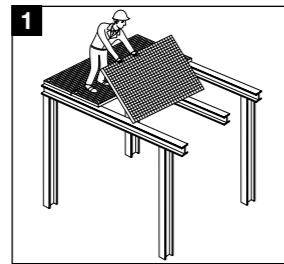

1 Lay grating section in final position.

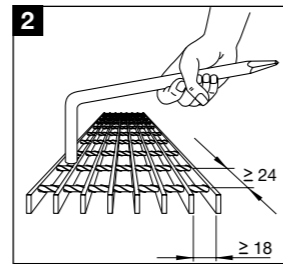

2 Expand grating openings if necessary.

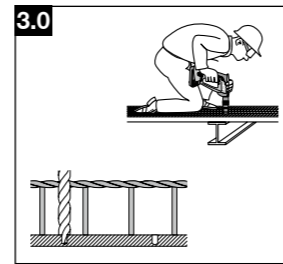

3.0 Pre-drill with **TX-BT 4/7** step shank drill bit.

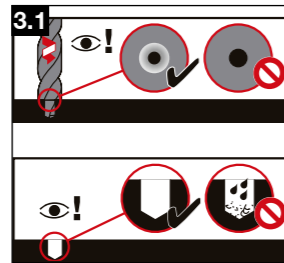

3.1 Pre-drill until shoulder grinds a shiny ring. The drill hole and the area around drilled hole must be clean and free from liquids and debris.

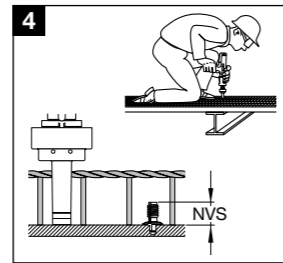

4 Drive fastener only with **DX 351 BT G** tool and 6.8/11M brown cartridge.

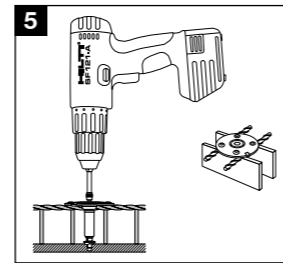

5 Tighten **X-FCM-R** with 5 mm Allen-type bit.

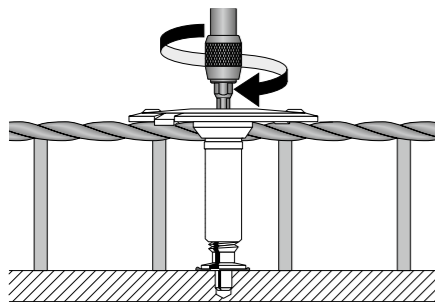

Installation details

Hand start to ensure no cross threading, then tighten using screwdriver with torque clutch.

Tightening torque: 5-8 Nm [3.7-5.9 ft-lb]

Tightening tool:

- Screwdriver with torque release coupling (TRC)
- 5 mm Allen-type bit

| Hilti screwdriver | Torque setting |
|-------------------|----------------|
| SF 121-A | 6 - 10 |
| SF 150-A | 5 - 8 |
| SF 14 | 5 - 8 |
| SF 14-A | 6 - 10 |
| SF 18-A | 5 - 8 |
| SFC 18-A | 5 - 8 |
| SF 22-A | 5 - 8 |

2.2 X-BT and MQ installation channel system

MQ installation channel on coated steel (electrical installation and small-bore piping)

Note: In case of applied shear load, the X-BT should be placed according to illustration (end of slotted hole)

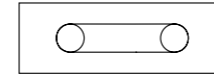

Two **X-BT** studs in one slotted hole



One **X-BT** stud in each slotted hole

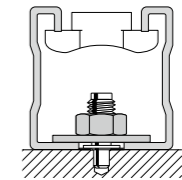
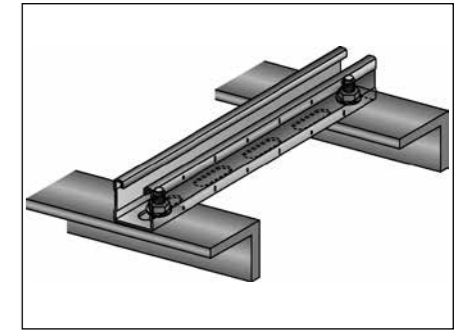

Fastening MQ brackets and bases for raised floor

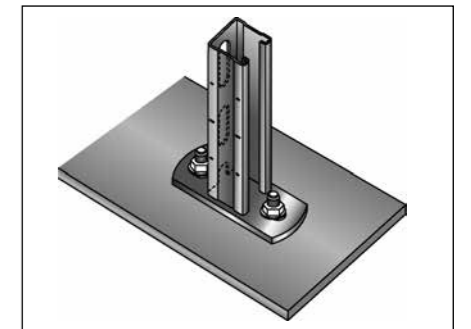

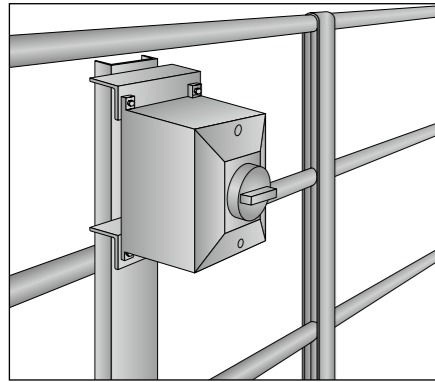

2.3 Fastening instrumentation, junction boxes and lighting

X-BT stainless steel threaded stud for attaching instrumentation, junction boxes and lighting to coated steel and high-strength steel

Installation instructions

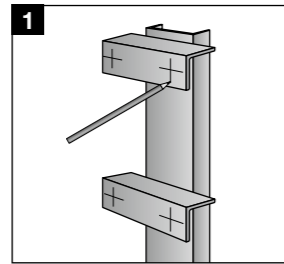

1 Mark location of each fastening.

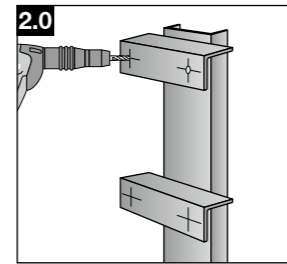

2.0 Pre-drill with **TX-BT 4/7** step shank drill bit.

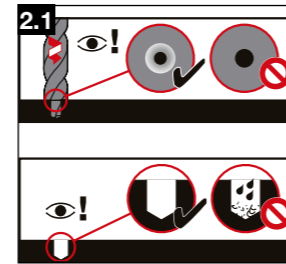

2.1 Pre-drill until shoulder grinds a shiny ring. The drill hole and the area around drilled hole must be clean and free from liquids and debris.

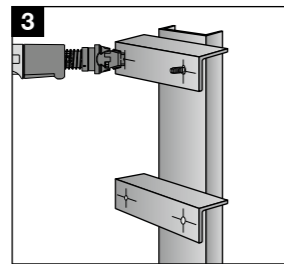

3 Drive **X-BT-R** studs with **DX 351 BT** tool and **X-BT** cartridge.

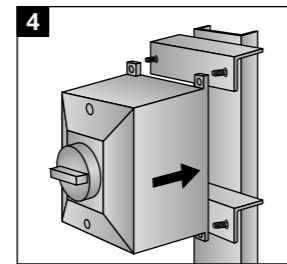

4 Position unit on studs and hold in place. Fit washers and start tightening by hand to avoid cross threading.

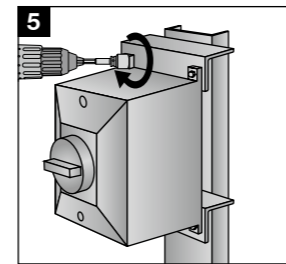

5 Tighten using a screwdriver with torque clutch. ($T_{rec} \leq 8 \text{ Nm} / 5.9 \text{ ft-lb}$)

2.4 Fastening cable/conduit connectors

X-BT threaded stud for cable/conduit connectors. Stainless steel threaded stud for fastening cable and conduit connectors (T-bars) to coated steel and/or high-strength steel

Installation instructions

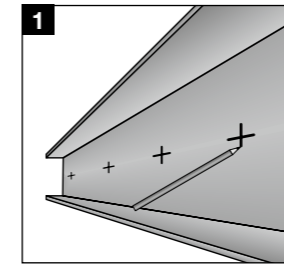

1 Mark location of each fastening.

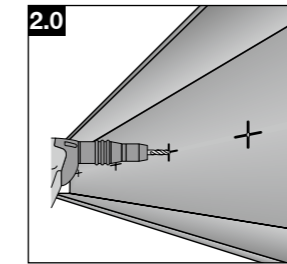

2.0 Pre-drill with **TX-BT 4/7** step shank drill bit.

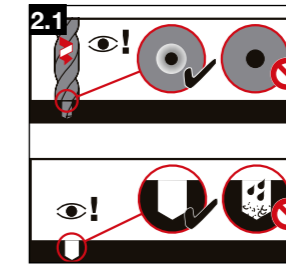

2.1 Pre-drill until shoulder grinds a shiny ring. The drill hole and the area around drilled hole must be clean and free from liquids and debris

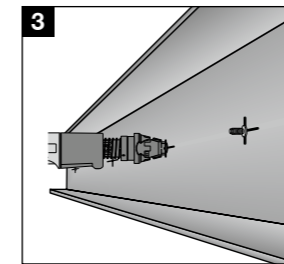

3 Drive fastener only with **DX 351 BT** tool and 6.8/M brown cartridge.

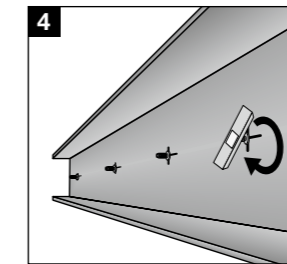

4 Screw on the connector and hand tighten. ($T_{rec} \leq 8 \text{ Nm} / 5.9 \text{ ft-lb}$)

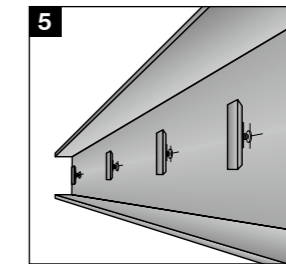

5 Align connectors.

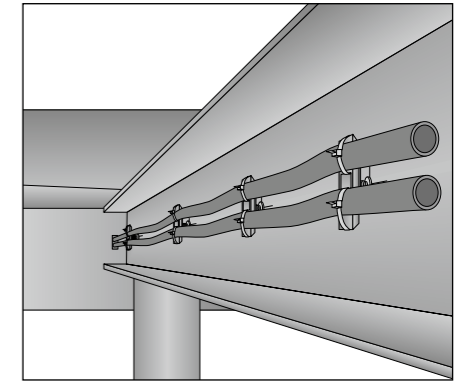

2.5 Fastening cable tray supports

X-BT stainless steel stud for fastening cable trays to coated and / or high-strength steel

Installation instructions

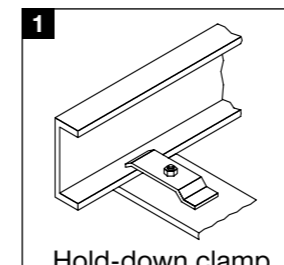

1 Hold-down clamp

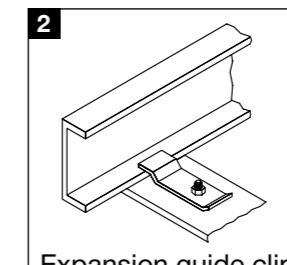
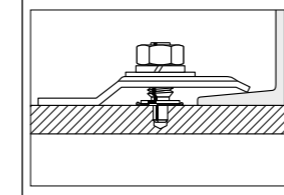

2 Expansion guide clip

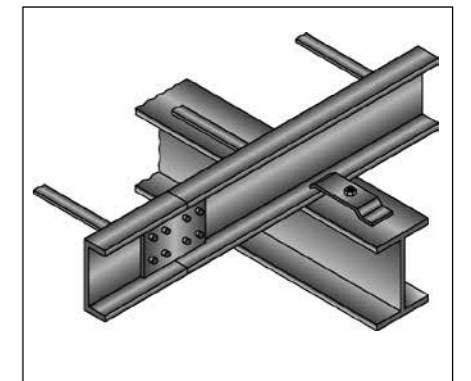
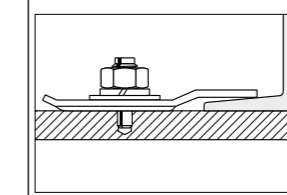

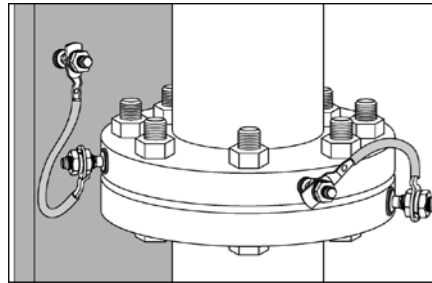

Functional and protective bonding in pipe (Outer diameter of installed surface $\geq 150\text{mm}$)

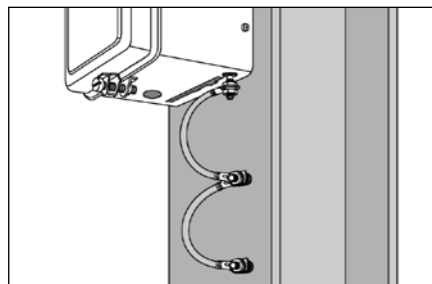

Protective bonding circuit - Double point connection

Single point connection

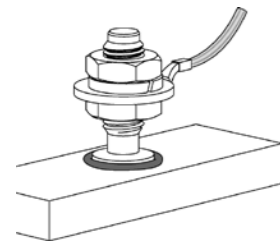

Single point connection

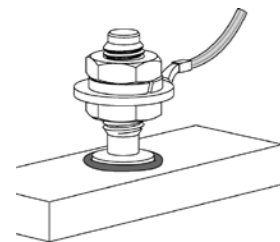

2.6 X-BT-ER stainless steel threaded studs for electrical connections

Fasteners

X-BT-ER M10/3 SN 4
X-BT-ER W10/3 SN 4

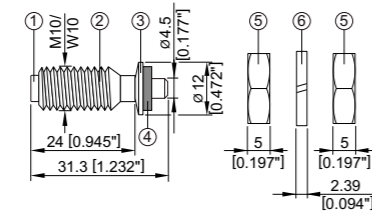

X-BT-ER M8/7 SN 4

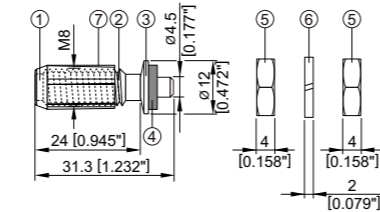

X-BT-ER M6/7 SN 4
X-BT-ER W6/7 SN 4

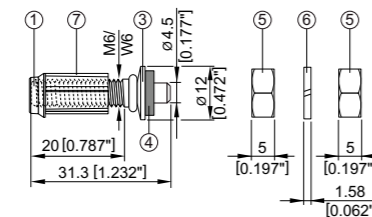

Please contact Hilti for additional technical information with regards to the effect of X-BT fasteners on integrity of pipe flange.

2.6.1 Functional Bonding and Terminal connection in a circuit

For low permanent current due to static charge built up in pipes or for low permanent current when closing an electrical circuit

Recommended electrical connectors: Max. allowable permanent current = 40A

- X-BT-ER M10/3 SN 4
- X-BT-ER W10/3 SN 4
- X-BT-ER M8/7 SN 4
- X-BT-ER M6/7 SN 4
- X-BT-ER W6/7 SN 4

Note:

- Recommended connected cable size (tested to 40A) according to IEC/EN 60204-1: $\leq 10\text{mm}^2$ copper ($\leq 8\text{AWG}$). Fastening of thicker cable is acceptable provided the maximum permanent current of 40A is not exceeded and the provisions on cable lug thickness are observed.

2.6.2 Protective bonding circuit

For discharging short circuit current while protecting electrical equipment or earth / ground or bond cable trays and ladders.

Recommended electrical connectors: Max. short circuit current for period of 1s = 1250A

- X-BT-ER M10/3 SN 4
- X-BT-ER W10/3 SN 4
- X-BT-ER M8/7 SN 4
- X-BT-ER M6/7 SN 4
- X-BT-ER W6/7 SN 4

Note:

- Recommended connected cable size (tested to 1250A for 1s) following IEC/EN 60947-7-2: $\leq 10\text{mm}^2$ copper ($\leq 8\text{AWG}$). Fastening of thicker cable is acceptable provided the maximum current of 1250A for a period of 1 second is not exceeded and the provisions on cable lug thickness are observed.
- Recommended connected cable size (tested to 750A for 4s) according to UL 467: $\leq 10\text{AWG}$

Recommended electrical connectors:

- X-BT-ER M8/7 SN 4
- X-BT-ER M6/7 SN 4
- X-BT-ER W6/7 SN 4

Max. short circuit current for period of 1s = 1800A

Note:

- Recommended connected cable size (tested to 1800A for 1s) following IEC/EN 60947-7-2: $\leq 16\text{mm}^2$ copper ($\leq 6\text{AWG}$). Fastening of thicker cable is acceptable provided the maximum current of 1800A for a period of 1 second is not exceeded and the provisions on cable lug thickness are observed.

2.6.3 Lightning protection

For high temporary current due to lightning.

Recommended electrical connectors:

- X-BT-ER M10/3 SN 4
- X-BT-ER W10/3 SN 4
- X-BT-ER M8/7 SN 4
- X-BT-ER M6/7 SN 4
- X-BT-ER W6/7 SN 4

Maximum current (According to EN50164-1 and EN 50164-1/prA:2005): $\leq 50\text{kA}$ for 2ms

When one nut is utilized and cable lug is in contact with base material.

- Cable lug must be in direct contact with non-coated base material.
- Extra M10/W10 SS washer to be used and installed between lock washer and cable lug.
- Base material must not contact the X-BT-ER SN washer, lock washer and nut.
- Cable lug thickness = 2mm to 12mm. Cable lug hole diameter $\geq 13\text{mm}$.
- **Max. tightening torque = 8Nm.**

Recommended electrical connectors:

- X-BT-ER M10/3 SN 4
- X-BT-ER W10/3 SN 4
- X-BT-ER M8/7 SN 4
- X-BT-ER M6/7 SN 4
- X-BT-ER W6/7 SN 4

Maximum tested current $\leq 100\text{kA}$ for 2ms

Double-point connection

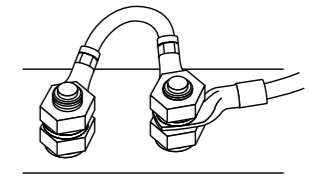

Single point connection

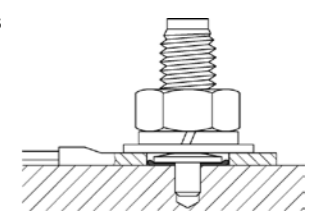
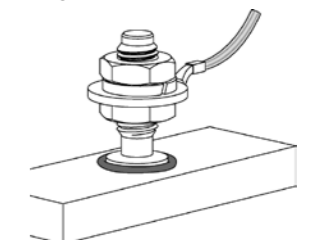

3. Technical data

3.1 Product data

3.1.1 X-BT material specifications

| | | |
|--------------------|--|---|
| ① Shank: | CR500 (CrNiMo alloy) S31803 (1.4462) N 08926 (HCR, 1.4529) ¹⁾ | equivalent to A4 / AISI grade 316 material available on request |
| ② Threaded sleeve: | X5CrNiMo 17-12-2+2H, 1.4401 | |
| ③ SN12-R washers: | S 31635 (X2CrNiMo 17-12-2, 1.4404) | |
| ④ Sealing washers: | Elastomer, black, resistant to UV, salt water, water, ozone, oils, etc. | |
| ⑤ Guide washer: | plastic | |

Designation according to Unified Numbering System (UNS)

¹⁾ For high corrosion resistance HCR material inquire at Hilti.

X-BT W10-24-6 SN12-R
X-BT M10-24-6 SN12-R

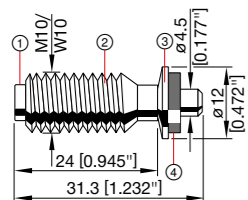

X-BT M8-15-6 SN12-R

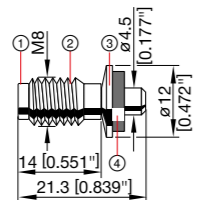

X-BT W6-24-6 SN12-R
X-BT M6-24-6 SN12-R

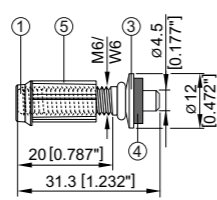

X-BT W10-24-6-R
X-BT M10-24-6-R

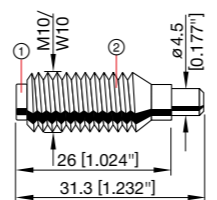

X-BT M8-15-6-R

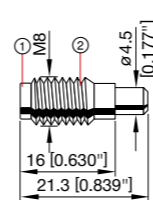

3.1.2 X-BT-ER material specifications

| | | |
|--------------------|---|---|
| ① Shank: | CR500 (CrNiMo alloy) S31803 (1.4462) | equivalent to A4 / AISI grade 316 material |
| ② Threaded sleeve: | X5CrNiMo 17-12-2+2H, 1.4401 | |
| ③ SN12-R washers: | S 31635 (X2CrNiMo 17-12-2, 1.4404) | |
| ④ Sealing washers: | Elastomer, black, resistant to UV, salt water, water, ozone, oils, etc. | |
| ⑤ Nuts: | A4 / AISI grade 316 material | |
| ⑥ Lock washers: | A4 / AISI grade 316 material | |
| ⑦ Guide sleeve: | plastic | |

X-BT-ER M10/3 SN 4
X-BT-ER W10/3 SN 4

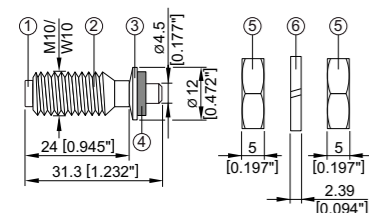

X-BT-ER M8/7 SN 4

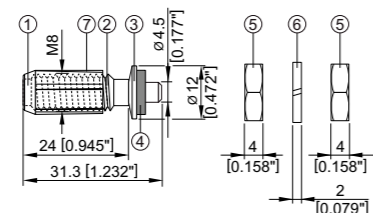

X-BT-ER M6/7 SN 4
X-BT-ER W6/7 SN 4

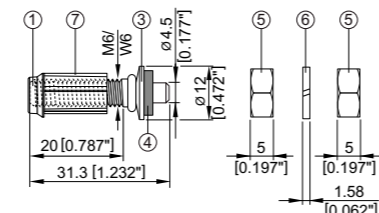

3.1.3 Fastening tool

DX 351-BT / BTG, see fastener selection in section 3.3.5.

3.1.4 Approvals

ABS, DNV, GL, LR, ICC ESR-2347, UL



The X-BT fastening systems holds several Type Approvals internationally valid for the ship-building and off-shore industry. These approvals are issued by international classification bodies relevant for these industries.

These bodies are:

- ABS – American Bureau of Shipping
- DNV – Det Norske Veritas
- GL – Germanischer Lloyd
- LR – Lloyds Register
- BV- Bureau Veritas
- Russian Maritime Register

The ICC-ES approval ESR-2347 covers application of the X-BT in building construction. ESR-2347 allows for the use of X-BT in compliance with the 2012 International Building Code (2012 IBC).

The UL-listing (File E257069) addresses the use of X-BT as grounding and bonding equipment.

Chapter 6 summarizes print-outs of the Type Approvals as well as the ESR-2347. These printouts allow for a general survey of the scope of the approvals, being valid end of April 2015.

Approvals are subject to continuous changes related to code developments (like ESR-2347), product portfolio updates and new research results. Current approvals can be downloaded from Hilti website or from the websites of most Certification Bodies.

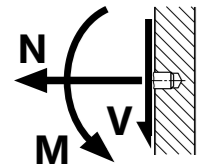

3.2 Load data

3.2.1 Loads - steel base material

Recommended loads – steel base material

| Steel grade: | S235, Europe, USA | S355, grade 50 and stronger steel |
|-----------------------------|----------------------|--------------------------------------|
| Tension, N_{rec} [kN/lb] | 1.8 / 405 | 2.3 / 517 |
| Shear, V_{rec} [kN/lb] | 2.6 / 584 | 3.4 / 764 |
| Moment, M_{rec} [Nm/ftlb] | 8.2 / 6 | 8.2 / 6 |
| Torque, T_{rec} [Nm/ftlb] | 8 / 5.9 | 8 / 5.9 |

Conditions for recommended loads

- Global factor of safety for static pull-out > 3 (based on 5% fractile value) ≥ 5 (based on mean value)
- Minimum edge distance = 6 mm [1/4"].
- Effect of base metal vibration and stress considered.
- Redundancy (multiple fastening) must be provided.

Note: This includes the potential moment acting on the fastener shank due to prying forces.

Design resistance - steel

| Steel grade: Europe | S235 | S355 |
|------------------------|------|------|
| Tension, N_{Rd} [kN] | 2.9 | 3.7 |
| Shear, V_{Rd} [kN] | 4.2 | 5.4 |
| Moment, M_{Rd} [Nm] | 18.4 | 18.4 |

Cyclic loading

- Anchorage of X-BT threaded stud in steel base material has been shown in laboratory testing to be resistant to cyclic loading.
- Fatigue strength is governed by fracture of the shank. The characteristic number of loads cycles N_K at 1.8 kN amounts to approximately 0.5 million, based on laboratory testing. Ask Hilti for more detailed test data if high cyclic loading has to be considered in the design.

3.2.2 Loads – cast iron base material*

Recommended loads – cast iron base material*

| | |
|-----------------------------|------------|
| Tension, N_{rec} [kN/lb] | 0.5 / 115 |
| Shear, V_{rec} [kN/lb] | 0.75 / 170 |
| Moment, M_{rec} [Nm/ftlb] | 8.2 / 6 |

Design resistance – cast iron*

| | |
|------------------------|------|
| Tension, N_{RD} [kN] | 0.8 |
| Shear, V_{RD} [kN] | 1.2 |
| Moment, M_{RD} [Nm] | 13.1 |

*Requirements of spheroidal graphite cast iron base material

| Subject | Requirements |
|----------------------|---|
| Cast iron | Spheroidal graphite cast iron according to EN 1563 |
| Strength class | EN-GJS-400 to EN-GJS-600 according to EN 1563 |
| Chemical analysis | |
| and amount of carbon | 3.3 - 4.0 mass percentage |
| Microstructure | From IV to VI (spherical) according to EN ISO 945-1:2010 |
| | Minimum size 7 according to figure 4 of EN ISO 945-1:2010 |
| Material thickness | $t_{II} \geq 20$ mm |

Recommended interaction formula for combined loading - steel and cast iron base material

| Combined loading situation | Interaction formula |
|------------------------------------|---|
| V-N (shear and tension) | $\frac{V}{V_{rec}} + \frac{N}{N_{rec}} \leq 1.2$ with $\frac{V}{V_{rec}} \leq 1.0$ and $\frac{N}{N_{rec}} \leq 1.0$ |
| V-M (shear and bending) | $\frac{V}{V_{rec}} + \frac{M}{M_{rec}} \leq 1.2$ with $\frac{V}{V_{rec}} \leq 1.0$ and $\frac{M}{M_{rec}} \leq 1.0$ |
| N-M (tension and bending) | $\frac{N}{N_{rec}} + \frac{M}{M_{rec}} \leq 1.0$ |
| V-N-M (shear, tension and bending) | $\frac{V}{V_{rec}} + \frac{N}{N_{rec}} + \frac{M}{M_{rec}} \leq 1.0$ |

3.3 Application requirements and limits

3.3.1 Thickness of fastened material - X-BT

| | |
|----------------------|---------------------------|
| X-BT M8: | $2.0 \leq t_f \leq 7$ mm |
| X-BT M10 / X-BT W10: | $2.0 \leq t_f \leq 15$ mm |
| X-BT M6 / X-BT W6: | $1.0 \leq t_f \leq 14$ mm |

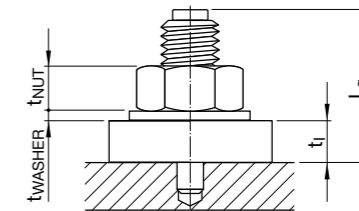

3.3.2 Thickness of cable lug - X-BT-ER

X-BT-ER M10/W10
 $t_c \leq 3$ mm (0.12")

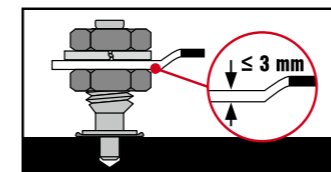

X-BT-ER M8 / X-BT-ER M6/W6
 $t_c \leq 7$ mm (0.28")

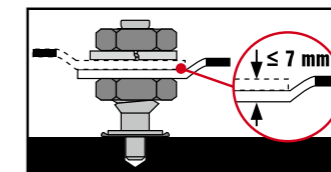

3.3.3 Spacing and edge distances

Spacing: ≥ 15 mm

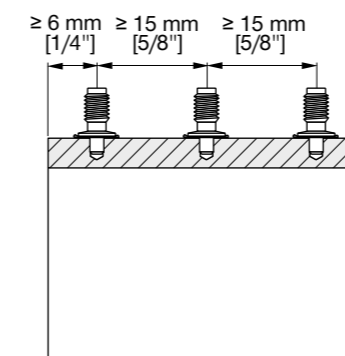

Edge distance: ≥ 6 mm

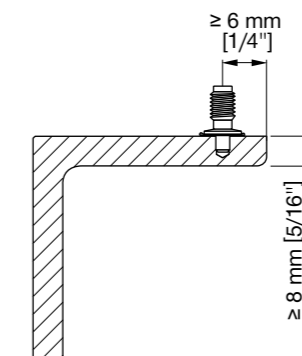

3.3.4 Application limit/thickness of base material

$t_{II} \geq 8$ mm [5/16"] → No through-penetration. No limits with regard to steel strength.

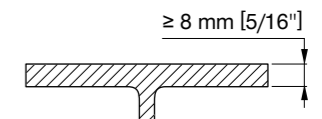

3.3.5 Fastener selection

| Fastener | Item number | Fastening tool | Fastening components | Cartridge | Step shank drill bit |
|--|-------------|---------------------|--|---|------------------------------------|
| For grating application | | | | | |
| X-BT M8-15-6 SN12-R | 377074 | Tool: DX 351 BTG | Fastener guide: X-351-BT FG G (item no: 378675) Piston: X-351-BT P G (item no: 378677) | | |
| X-BT M8-15-6-R (without washer) * | 377073 | | | | |
| For multi-purpose fastening application | | | | | |
| X-BT M10-24-6 SN12-R | 377078 | Tool: DX 351 BT | Fastener guide: X-351-BT FG M1024 (item no: 378674) Piston: X-351-BT P 1024 (item no: 378676) | 6.8/11 M brown High Precision (item no: 412689) | TX-BT 4/7-80 (item no: 377079) |
| X-BT M10-24-6-R (without washer) * | 377077 | | | | |
| X-BT M8-24-6 SN12-R ** | - | | | | |
| X-BT M6-24-6 SN12-R | 432266 | | | | |
| X-BT W10-24-6 SN12-R | 377076 | | Fastener guide: X-351-BT FG W1024 (item no: 378673) Piston: X-351-BT P 1024 (item no: 378676) | | TX-BT 4/7-110 (item no: 377080) |
| X-BT W10-24-6-R (without washer) * | 377075 | | | | TX-BT 4/7-150 (item no: 377081) |
| X-BT W6-24-6 SN12-R | 432267 | | | | |
| For electrical connection application | | | | | |
| X-BT-ER M10/3 SN 4 | 2103094 | Tool: DX 351 BT | Fastener guide: X-351-BT FG M1024 (item no: 378674) Piston: X-351-BT P 1024 (item no: 378676) | | |
| X-BT-ER M8/7 SN 4 | 2103095 | | | | |
| X-BT-ER M6/7 SN 4 | 2107275 | | | | |
| X-BT-ER W10/3 SN 4 | 2103093 | | Fastener guide: X-351-BT FG W1024 (item no: 378673) Piston: X-351-BT P 1024 (item no: 378676) | | |
| X-BT-ER W6/7 SN 4 | 2103096 | | | | |

Note:
 For High Corrosion Resistance HCR material inquire at Hilti (X-BT only).
 The three step shank drills only differ in their length. Their optimized use depends on the accessibility condition on the jobsite.
 The recommended tool energy setting = 1 (if required, increase of energy setting based on job site tests).
 * NQA-1-2000 compliant
 ** Please contact Hilti for availability.

3.3.6 Cartridge selection and tool power setting

6.8/11 M high-precision brown cartridge
 Fine adjustment by installation tests on site

3.3.7 Installation details - X-BT

- ① **X-BT with washer**
Fastened material hole diameter ≥ 13 mm ($> 1/2$ ")
- ② **X-BT without washer**
Fastened material hole diameter ≥ 11 mm ($> 3/8$ ") for X-BT M/W10
 ≥ 9 mm ($> 5/16$ ") for X-BT M8

X-BT M6 / X-BT W6

- ③ Fastened material with pre-drilled hole diameter < 7 mm ($9/32$ ")
- ④ Fastened material with pre-drilled hole diameter ≥ 7 mm ($9/32$ ") + washer

Note: pre drill hole diameter ≤ 10 mm ($3/8$ ").

Before fastener installation

The drilled hole must be clear of liquids and debris. The area around the drilled hole must be free from liquids and debris.

Tightening torque, **Trec** ≤ 8 Nm [5.9 ft-lb]!

| Hilti screwdriver | Torque setting |
|-------------------|----------------|
| SF 121-A | 11 |
| SF 150-A | 9 |
| SF 180-A | 8 |
| SF 144-A | 9 |
| SF 22-A | 9 |

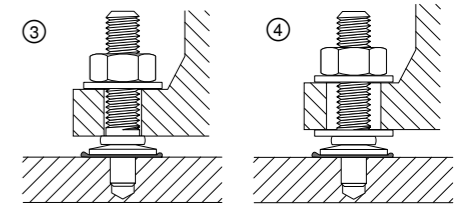
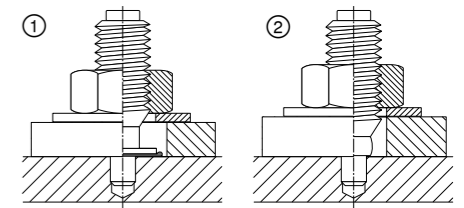
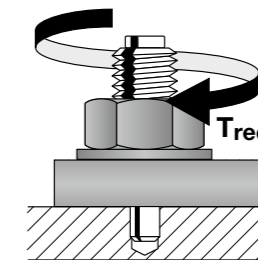

Pre-drill until the bit shoulder grinds a shiny ring (to ensure proper drilling depth).

3.3.8 Installation for electrical connections - X-BT-ER

Single point connection for all X-BT-ER

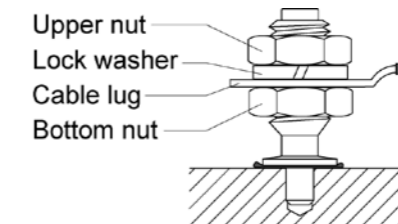
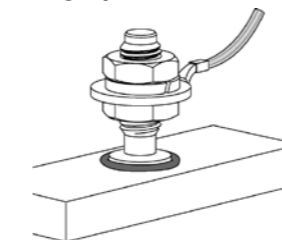

Double connection only for X-BT-ER M6/W6 and X-BT-ER M8

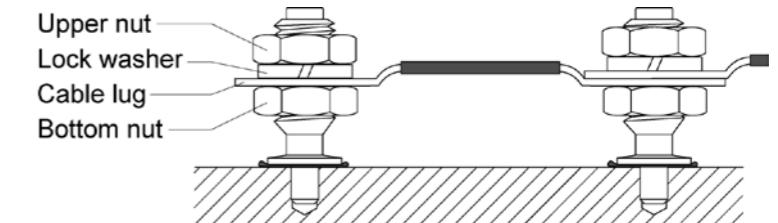
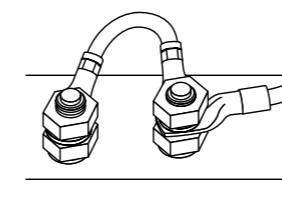

3.3.9 Fastening quality assurance

Fastening inspection

X-BT M8
 $h_{NVS} = 15.7-16.8$ mm

X-BT M10 / X-BT W10 and X-BT M6 / X-BT W6
X-BT-ER M/W10, X-BT-ER M8 and X-BT-ER M/W6
 $h_{NVS} = 25.7-26.8$ mm

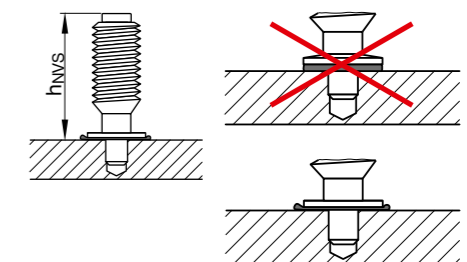

4. Method statement

4.1 Instructions for use - X-BT

| | | |
|----------------------|---------------|---------------|
| | | |
| X-BT M6-24-6 SN12-R | DX 351 BT (M) | TX-BT 4/7-80 |
| X-BT M10-24-6 SN12-R | | |
| X-BT W6-24-6 SN12-R | DX 351 BT (W) | |
| X-BT W10-24-6 SN12-R | | |
| X-BT M8-15-6 SN12-R | DX 351 BTG | TX-BT 4/7-110 |

4.2 Instructions for use - X-BT-ER M10/W10

| | | | |
|-----------------|-----------|-------------|--------------|
| | | | |
| X-BT-ER M10/W10 | DX 351 BT | X-BT 4000-A | TX-BT 4/7-80 |

Instructions for use are subject to continuous changes related to code developments, product portfolio updates, and new research results. Current instruction for use can be downloaded from Hilti website.

4.3 Instructions for use - X-BT-ER M6/W6/M8

| | | | |
|---------------|-----------|-------------|--------------|
| | | | |
| X-BT-ER M6/W6 | DX 351 BT | X-BT 4000-A | TX-BT 4/7-80 |

Instructions for use are subject to continuous changes related to code developments, product portfolio updates, and new research results. Current instruction for use can be downloaded from Hilti website.

5. Performance (technical reports)

5.1 Nomenclature and symbols, design concepts

The symbols and nomenclature used in the technical data are listed below.

Fastener test data and performance

| | |
|---|--|
| N and V | Tensile and shear forces in a general sense |
| F | Combined force (resulting from N and V) in a general sense |
| N_S and V_S | Tensile and shear forces acting on a fastening in a design calculation |
| F_S | Combined force (resulting from N_S and V_S) in a design calculation |
| N_u and V_u | Ultimate tensile and shear forces that cause failure of the fastening, statistically, the reading for one specimen |
| N_{u,m} and V_{u,m} | Average ultimate tensile and shear forces that cause failure of the fastening, statistically, the average for a sample of several specimens |
| S | The standard deviation of the sample |
| N_{Rk} and V_{Rk} | Characteristic tensile and shear resistance of the fastening, statistically, the 5 % fractile. For example, the characteristic strength of a fastening whose ultimate strength can be described by a standard Gauss type distribution is calculated by: N_{Rk} = N_{u,m} - k x S where k is a function of the sample size, n and the desired confidence interval. |
| N_{rec} and V_{rec} | Recommended maximum tensile and shear loads for the fastener shank: N_{rec} = $\frac{N_{Rk}}{\nu}$ and V_{rec} = $\frac{V_{Rk}}{\nu}$ where ν is the overall factor of safety |
| M_{rec} | Recommended working moment for the fastener shank M_{rec} = $\frac{M_{Rk}}{\nu}$ where M_{Rk} is the characteristic moment resistance of the fastener shank and ν is an overall factory of safety. Unless otherwise stated on the product data sheets, the M_{rec} values in this manual include a safety factor of "2" for static loading. |

Fastening details

| | |
|------------------------|---|
| h_{ET} | Penetration of the fastener point below the surface of the base material |
| h_{NVS} | Nail head standoff above the surface fastened into (with nails, this is the surface of the fastened material, with threaded studs, the surface of the base material). |
| t_{II} | Thickness of the base material |
| t_I | Thickness of the fastened material |
| ∑ t_i | Total thickness of the fastened material (where more than one layer is fastened) |
| t_{cl} | Thickness of cable lug (for X-BT-ER) |

Characteristics of steel and other metals

| | |
|---|--|
| f_y and f_u | Yield strength and ultimate strength of metals (in N/mm ² or MPa) |
|---|--|

Design concepts

The recommended working loads (**N_{rec}** and **V_{rec}**) are generally suitable for use in typical working load designs.

If the X-BT has to be designed in accordance with a partial safety concept, the recommended loads have to be multiplied by the global safety factor, applicable to the respective design concept, to calculate the characteristic loads **N_{Rk}** and **V_{Rk}**. E.g. in case of a design in compliance with the Eurocodes, the global safety factor would be 2.

Working load concept

$$N_S \leq N_{rec} = \frac{N_{Rk}}{\nu}$$

where ν is an overall factor of safety including allowance for:

- errors in estimation of load
- deviations in material and workmanship

and **N_S** is, in general, a characteristic acting load.

$$N_S \equiv N_{Sk}$$

Partial safety concept

$$N_{Sd} \leq N_{Rd}$$

$$N_{Sd} = N_{Sk} \times \gamma_F$$

$$N_{Rd} = N_{Rk} / \gamma_m$$

where γ_F is a partial factor of safety to allow for errors in estimation on the acting load.

γ_m is a partial factor of safety to allow for deviations in material and workmanship.

This summary is intended to be representative of the test(s) carried out. It is not intended to be a full and complete test report.

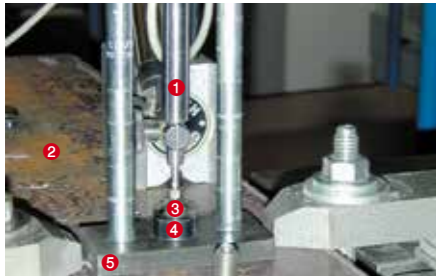

- 1 Displacement sensor
- 2 Base steel
- 3 X-BT-M10-24-6
- 4 Special nut, M10
- 5 Loading plate

5.2 Static capacity of the X-BT threaded stud

5.2.1 Tensile load deformation behavior of X-BT threaded stud fastenings

Load-displacement behavior of blunt-tip stainless steel threaded studs,

Report No. XE_02_03; Reinhard Buhri; January 2002

Evaluation report on 5S (X-BT)-fastenings,

Report No. XE_02_36; Hermann Beck, July 2002

| | |
|------------------------------|--|
| Base material | Steel, 20mm thick, $f_u = 385 \text{ MPa}$ (S235) and $f_u = 630 \text{ MPa}$ (S355) |
| Number of fastenings in test | 11 (6 in S235, 5 in S355) |

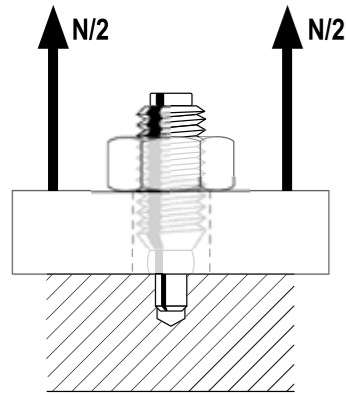

- 1 Load-displacement curve of one specimen selected as being representative for the five specimens tested.
- 2 Load-displacement curve of one specimen selected as being representative for the six specimens tested.

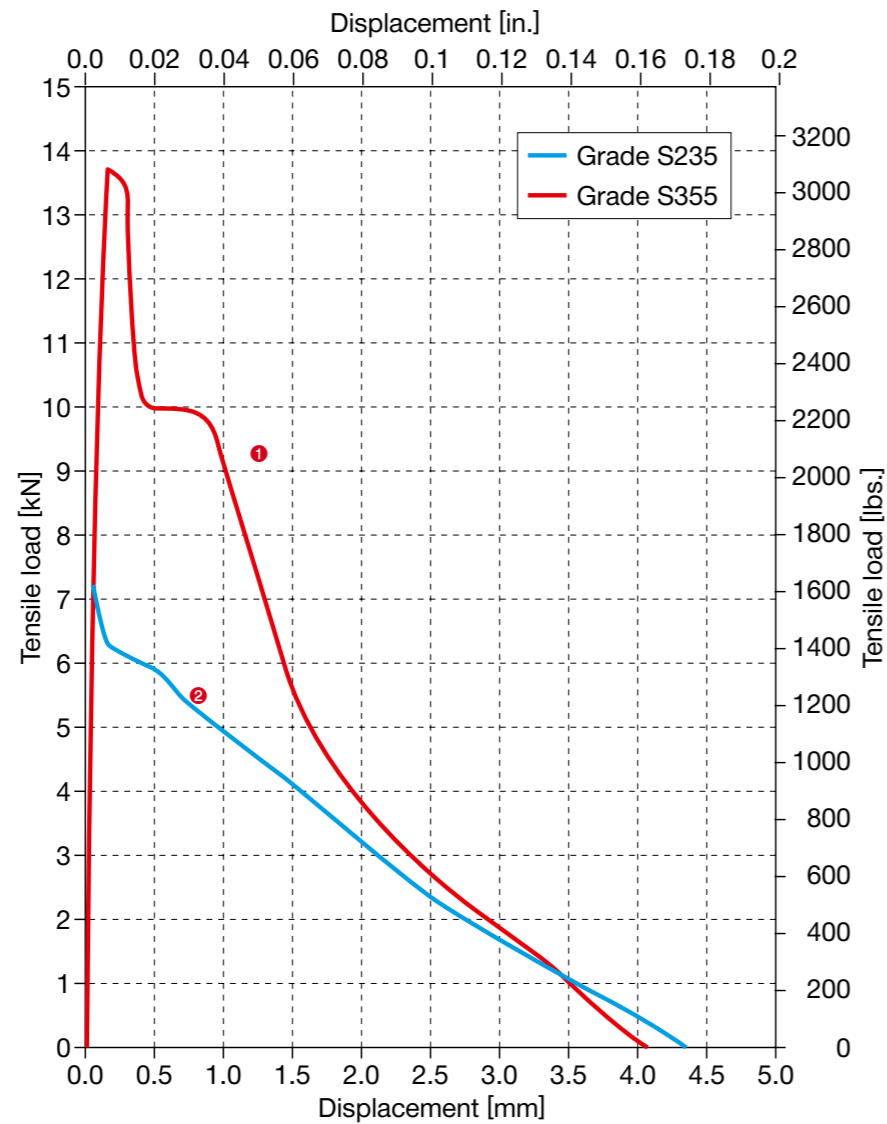

Conclusions

- Very stiff up to maximum load
- Significant resistance to pull-out even after relatively large displacement
- Ultimate pull-out loads increase with increasing base steel strength
- The continued resistance during pull-out and the dependency of ultimate pull-out load on base steel strength indicates that the fastener fuses with the base steel

This summary is intended to be representative of the test(s) carried out. It is not intended to be a full and complete test report.

5.2.2 Pull-out strength of X-BT threaded stud fastenings

Load behavior on special steel constructions,

Report No. XE_01_57; Reinhard Buhri; 30 November 2001

Pull-out strength of blunt tip stainless steel threaded studs,

Report No. XE_02_23; Reinhard Buhri; 9 April 2002

| | |
|------------------------------|--|
| Base material | Steel, 6, 8, 10, 12 and 15 mm thick, S235 and S355 |
| Number of fastenings in test | 200 total, (20 per situation of thickness and steel grade) |

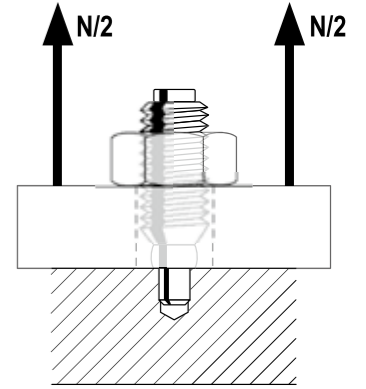

Ultimate pull-out load as a function of base steel ultimate tensile strength

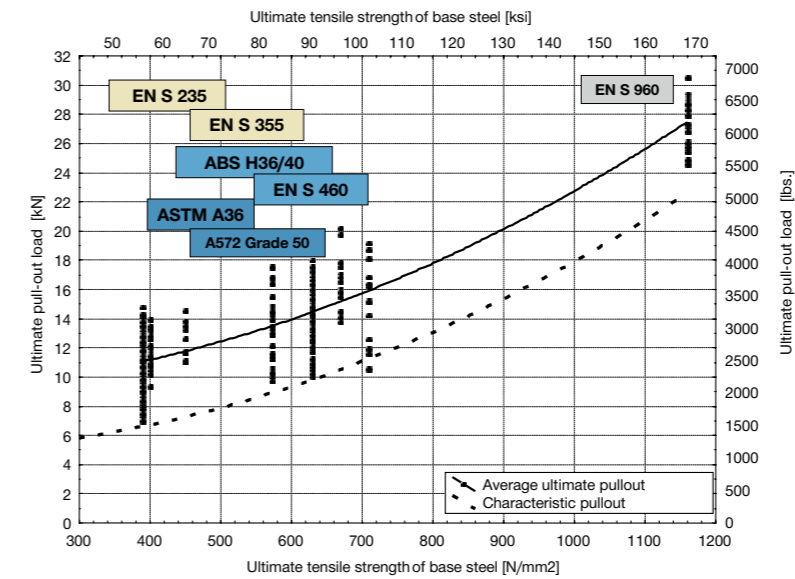

Ultimate pull-out load as a function of base steel thickness X-BT threaded studs in S235 [A36] steel

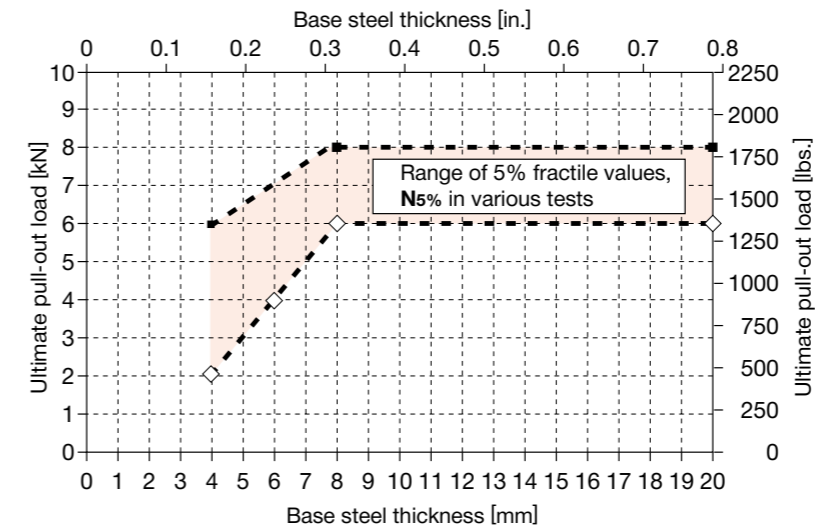

Conclusions

- For steel thickness $\geq 8 \text{ mm}$, 5% fractile pull-out $\geq 6 \text{ kN}$ without regard to steel grade
- Lower pull-out values with S235/A36
- Higher pull-out values with thermomechanical hot-rolled fine-grain steel according to ABS and EN 10025-4 and quenched and tempered high-grade steel according to EN 10025-6

This summary is intended to be representative of the test(s) carried out. It is not intended to be a full and complete test report.

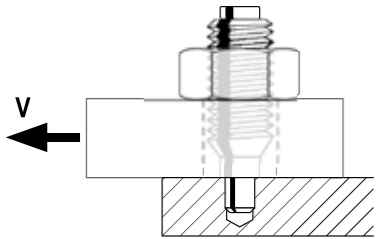

5.2.3 Shear strength of X-BT threaded stud fastenings

Evaluation report on 5S fastenings,

Report No. XE_02_36; Hermann Beck; 4 July 2002

Load behavior on static shear loading,

Report No. XE_01_45; Reinhard Buhri; 10 October 2001

| | |
|------------------------------|--|
| Base material | Steel, 8 to 10 mm thick, S235 and S355 |
| Fastened material | Steel, 15 mm thick |
| Number of fastenings in test | 12 (S235) and 8 (S355) |

Load-displacement behavior

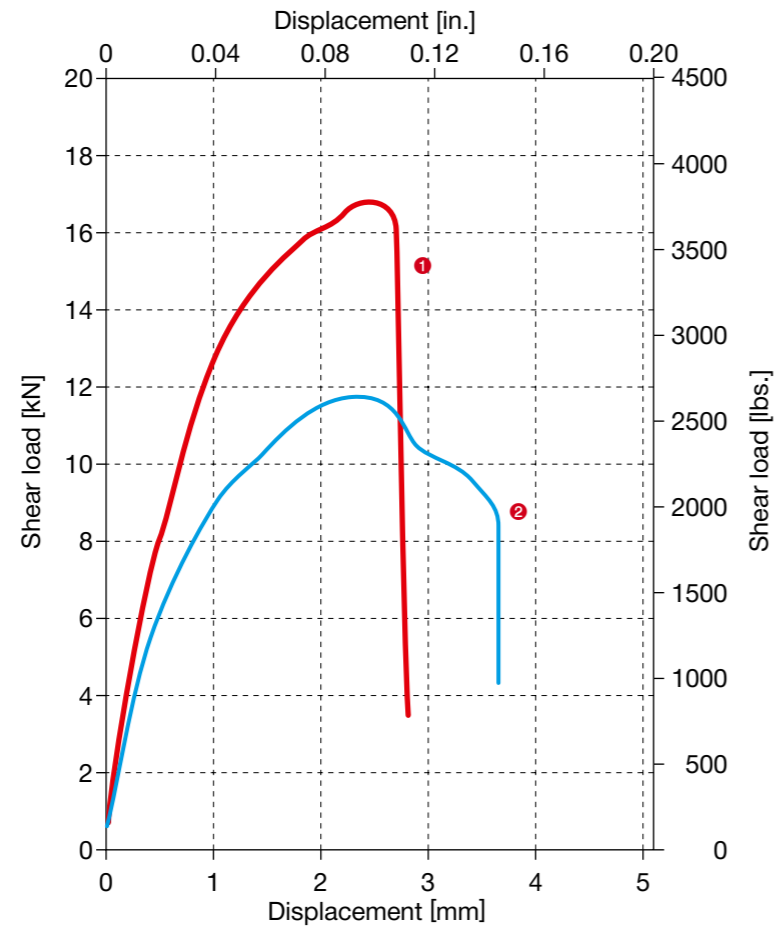

1 S355 steel

Load-displacement curve of one specimen selected as being representative for the eight specimens tested.

2 S235 steel

Load-displacement curve of one specimen selected as being representative for the twelve specimens tested.

| | Average ultimate shear $V_{u,m}$ [kN (lbs.)] | Deformation at $V_{u,m}$ [mm (in.)] | Mode of failure |
|----------------------------------|--|-------------------------------------|--|
| 1 S355 ($f_u = 630\text{MPa}$) | 16.77 (3770.0) | 2.45 (0.096) | 12% base steel failure + pull-out 88% fastener fracture |
| 2 S235 ($f_u = 390\text{MPa}$) | 12.02 (2702.2) | 2.42 (0.095) | 67% base steel failure + pull-out 33% fastener fracture |

Conclusions

- Shear strength of the fastening increases with base material strength
- Failure mode with high-strength steel (S355, Grade 50) predominately fastener fracture
- Failure mode with lower-strength steel (S235, A36) predominately base metal failure and pull-out

This summary is intended to be representative of the test(s) carried out. It is not intended to be a full and complete test report.

5.2.4 Effect of edge distance/spacing on pull-out strength of X-BT fastenings

Tensile and shear loading in small steel beams,

Report No. XE_02_39; Reinhard Buhri; 16 July 2002

Effect of edge distance and fastener spacing on ultimate pull-out,

Report No. XE_02_28; Reinhard Buhri; 23 April 2002

Stainless steel studs without point,

Report No. XE_02_23; Reinhard Buhri; 9 April 2002

Edge distance

| | |
|------------------------------|---|
| Base material | Steel, 8 mm thick, S235 ($f_u = 390\text{MPa}$) |
| Number of fastenings in test | 120 total, (20 per edge distance) |
| Edge distances tested | 3, 4, 5, 6, 7, 8 and 25 mm |

Test concept

- 1) Place groups of fastenings at various edge distances
- 2) Pull out all fastenings
- 3) Compare ultimate pull-out loads for the various groups to existing ultimate pull-out data

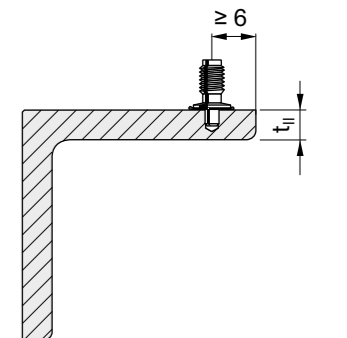
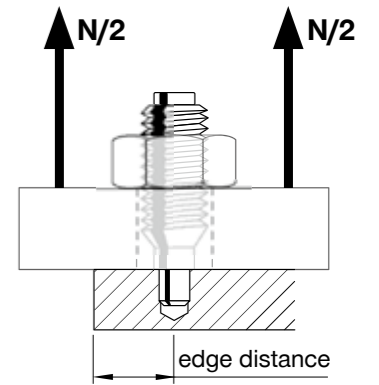
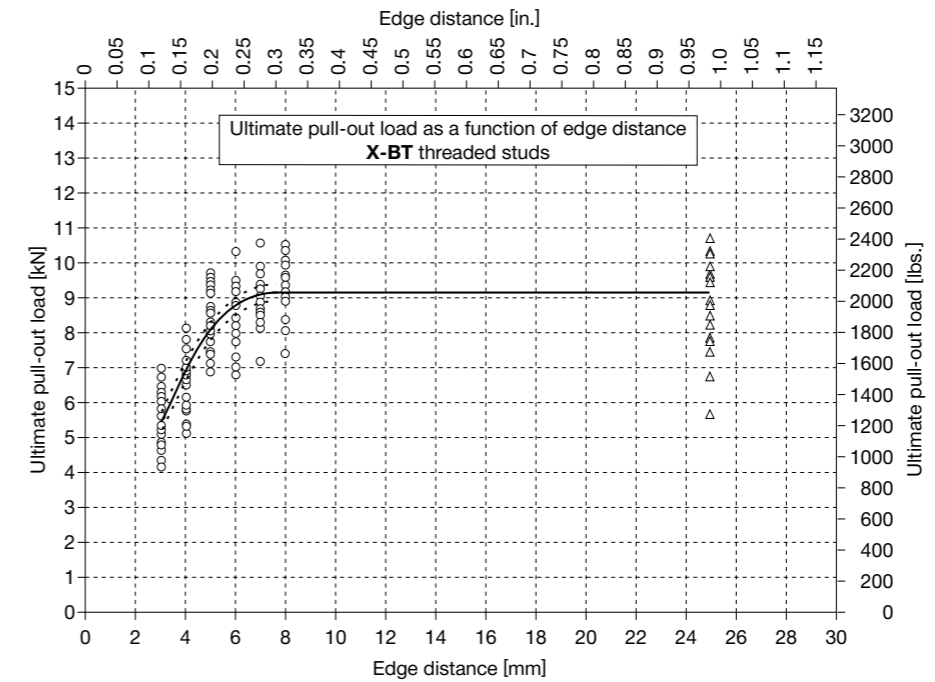

Conclusions

- Increasing the edge distance to more than 6 mm does not result in increased ultimate pull-out.
- An edge distance of 6mm is adequate to avoid reduction in recommended load.

This summary is intended to be representative of the test(s) carried out. It is not intended to be a full and complete test report.

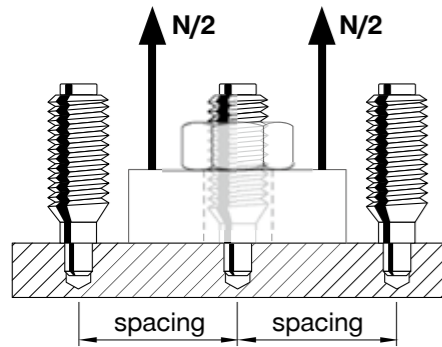

Tensile and shear loading in small steel beams,

Report No. XE_02_39; Reinhard Buhri; 16 July 2002

Effect of edge distance and fastener spacing on ultimate pull-out,

Report No. XE_02_28; Reinhard Buhri; 23 April 2002

Stainless steel studs without point,

Report No. XE_02_23; Reinhard Buhri; 9 April 2002

Fastening spacing

| | |
|------------------------------|--|
| Base material | Steel, 8 mm thick, S235 ($f_u = 390$ MPa) |
| Number of fastenings in test | 60 total, (20 per spacing) |
| Spacings tested | 15, 20 and 25 mm |

Test concept

- 1) Place groups of fastenings at various spacings
- 2) Pull out all fastenings
- 3) Compare pull-out loads of the various groups and to existing pull-out data

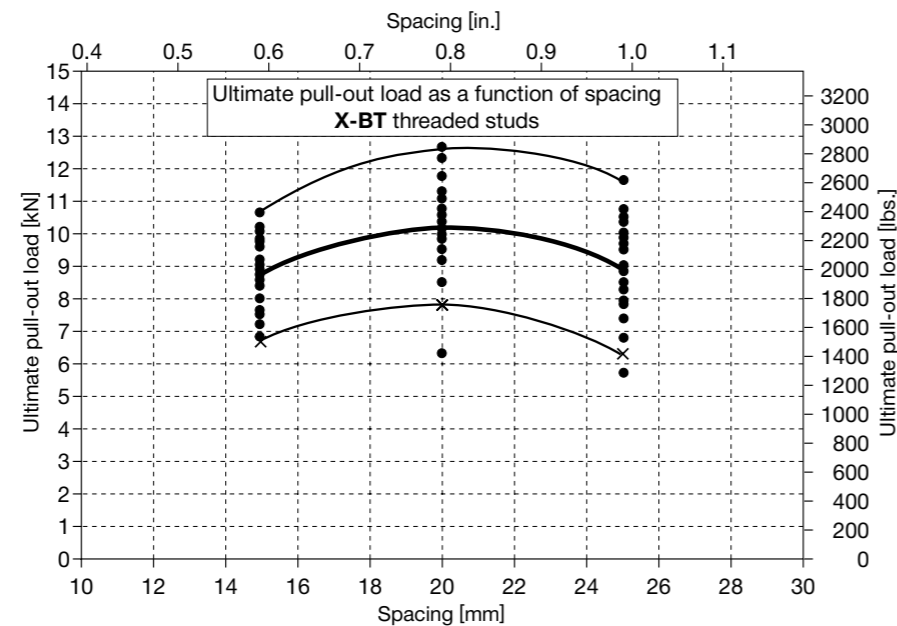
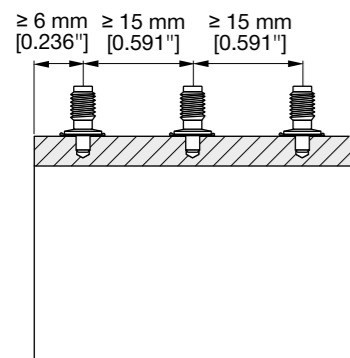

Conclusions

- Increasing the fastener spacing to more than the 15 mm as dictated by the base-plate on the DX 351 tool does not significantly increase ultimate pull-out.
- A fastener spacing of 15 mm is adequate to avoid reduction in recommended load.

This summary is intended to be representative of the test(s) carried out. It is not intended to be a full and complete test report.

5.2.5 Holding mechanisms of X-BT threaded studs

Anchoring mechanisms of the Hilti X-BT fastening system,

Rheinisch-Westfälische Technische Hochschule, Aachen,

Prof.-Ing. Wolfgang Bleck, 7 November 2002

Investigation of welding between stainless steel X-BT fastener and S235 /

S355 steel base material, Report TWU-IFM 213/01, Birgit Borufka, 2001

Load behavior of stainless steel studs without tip,

Report XE-01-05, Reinhard Buhri, March 2001

Investigation concept

- 1) Consider difference between X-CR austenitic stainless steel (corresponds to X2CrNiMoNbN25-18-5-4) and construction grade ferritic steels S235/S355 per DIN EN 10025 (similar to ASTM A36/A572 Grade 50).
- 2) Examination of metallographic cross-sections at various distances from the surface of the base steel.
- 3) Examination of pulled out X-BT fasteners.

Differences between fastener material and base steel material

- CR500 steel is 3 times harder than ferritic construction steel.

| | |
|-----------------------------------|---|
| CR500 austenitic stainless steel: | $f_u \geq 1850$ MPa |
| Construction grade steels | |
| S235 (per DIN EN 10025): | $f_y \geq 235$ MPa, $f_u = 340 - 510$ MPa |
| S355 (per DIN EN 10025): | $f_y \geq 355$ MPa, $f_u = 470 - 630$ MPa |

- The hardness of X-CR steel is less affected by increasing temperature than ferritic construction steel. Thus it can be concluded that the hardness difference is maintained during driving as well and a new surface is formed at the interface of base steel and fastener.

Examination of cross-section

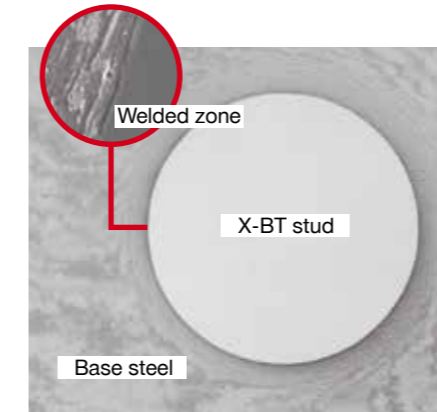

Examination of pulled-out X-BT threaded stud

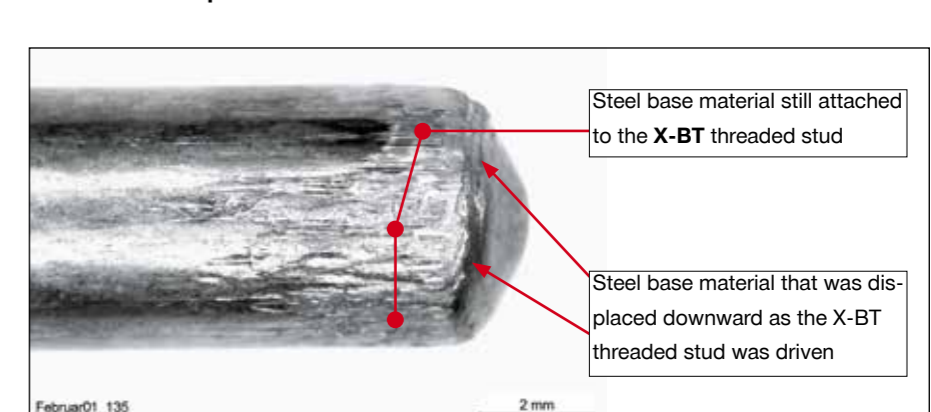

Description of the holding mechanism

- Anchorage of the X-BT fastener in steel develops due to friction and fusion (friction welding). The characteristics of friction welding are: concentrated heat development, grain refinement due to hot and cold working, and little diffusion across the interface of the welded components.
- A definite interface exists along the entire perimeter of the fastener shank
- The drilled hole below the tip of the X-BT threaded stud is sealed
- The interface of the fastener shank in each cross-section is between 55% and 100% welded to S235/A36 steel base material.
- The interface of the fastener shank in each cross-section is between 75% and 100% welded to S355/Grade 50 steel base material.

This summary is intended to be representative of the test(s) carried out. It is not intended to be a full and complete test report.

5.3 Corrosion resistance

5.3.1 X-BT threaded stud fastening corrosion data

Blunt-tip stainless steel stud with sealing washer,
Report No. XE_02_13; Reinhard Buhri; June 2002

Corrosion data

| | |
|------------------------------|--|
| Base material | Steel, 8 mm thick, S235 ($f_u = 385$ MPa) and S355 ($f_u = 630$ MPa) |
| Number of fastenings in test | 120 total, (60 per steel grade) |
| Salt spray test | 90 days, performed according to DIN 50 021SS / ASTM G 8585) |

Test concept

- 1) Make 60 fastenings in steel of each grade (S235 and S355 steel).
- 2) Perform pullout tests of 30 fastenings from each steel grade before performing the salt spray test.
- 3) Perform pullout tests of 30 fastenings from each steel grade after the salt spray test.
- 4) Compare the ultimate pull-out loads before and after the 90 day salt spray test for each steel grade.
- 5) Examine the area around the fastening points after pulling out the fasteners

Pull-out test results for S355 steel

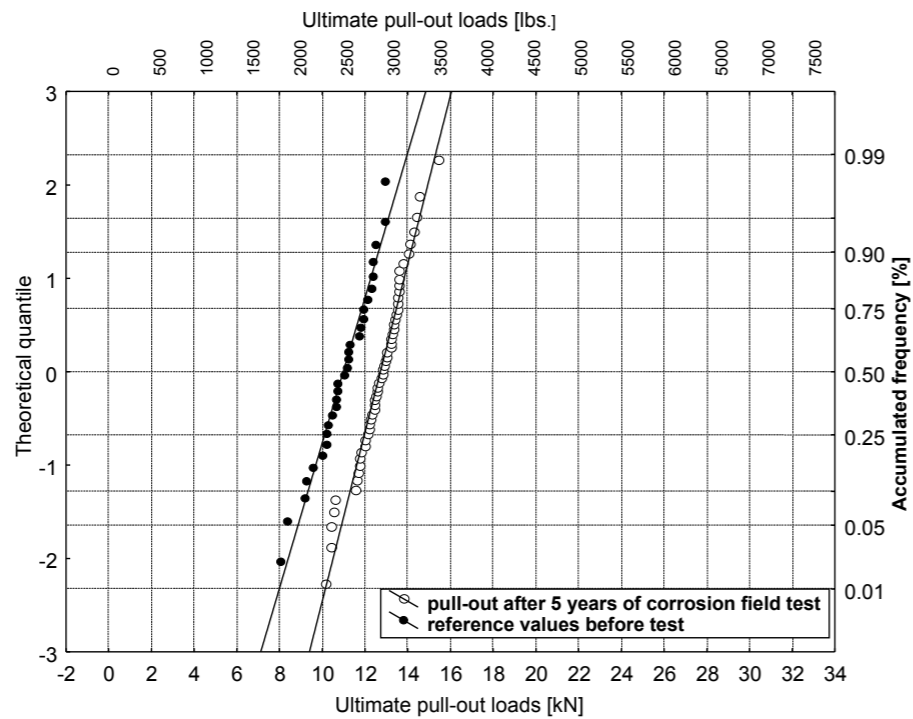

Summary of results from the pull-out tests

- Similar results for S235 steel grade.

This summary is intended to be representative of the test(s) carried out. It is not intended to be a full and complete test report.

Observations and examination

After 90 days of salt spray, the bottom side of the 8 mm [5/16"] steel plate was examined. No evidence of damage or corrosion could be found.

Corrosion resistance of Hilti CR500 stainless steel in comparison with AISI 304 and AISI 316;

FMPA Baden-Württemberg; Report No. VI.10.1.7c; July 2000

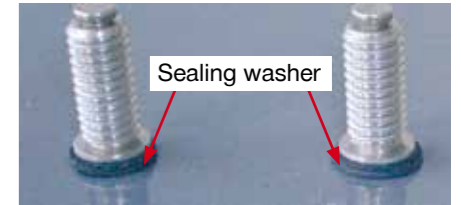
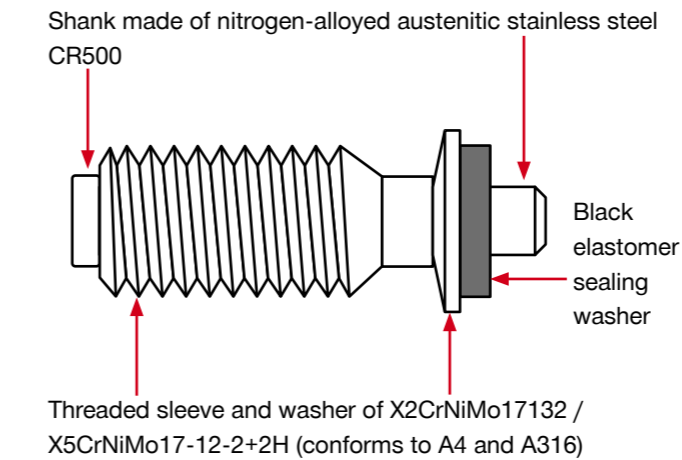

Prepared X-BT fastenings after driving



Drilled holes after 90 days salt spray test and after pull-out of the X-BT fasteners. These holes appear clean and no evidence of corrosion is visible.

Pitting potential in ASTM sea water

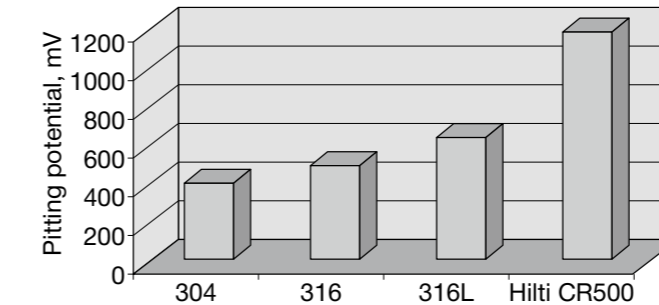

Potential-static test carried out with rods and nails in synthetic sea water as per ASTM D 1141

Conclusions from the tests

- Ultimate pull-out of the fastenings was not affected by 90 days of salt spray test.
- After 90 days salt spray test no corrosion was found in the drilled holes. This is strong evidence that the sealing washer provides an effective seal.
- After 90 days salt spray test, there was no evidence of corrosion on the bottom side of the steel plate. This shows that drilling the hole and driving the fastener does not cause damage on the bottom side.
- CR 500 is at least as resistant as AISI grade 316.

This summary is intended to be representative of the test(s) carried out. It is not intended to be a full and complete test report.

5.3.2 Contact corrosion – X-BT stainless steel stud in carbon steel

Corrosion behavior of X-CR fasteners,

Report No. VI.10.1.7; FMPA Stuttgart; May 1994.

Corrosion behavior of stainless steel DX fasteners in carbon steel;

G. Felder and M. Siemers, Schaan, September 2005

General comments

Two materials of different resistance/polarity exposed to the same media, in direct electrical contact, lead to accelerated corrosion of an electrochemically “less noble” material in contact with a “noble” material. The material loss of the noble partner is reduced, the loss of surface area of the less noble partner is increased. Prerequisite for this form of corrosion is an electrically conductive connection between these two materials.

Whether contact corrosion occurs depends also on the **surface area ratio**.



If the surface of the less “noble” material (1) is greater than that of the more “noble” material (2), it will act as a very small cathode and the current density on the “large anodic” less noble material will be very small. Further, this also implies a very low rate of corrosion of the “less noble” material due to electrochemical effects.



However, if the surface of the less “noble” material (1) is smaller than that of the more “noble” material (2), the rate of corrosion of the “less noble” material will be very high.

Hilti X-BT in carbon steel

Where stainless steels are concerned, contact corrosion is not a matter of concern. Stainless steels are higher in the galvanic series, i.e. more noble than most generally used materials such as aluminium, zinc and steel. Stainless steel in contact with these materials thus gains cathodic protection. Contact therefore generally has a favorable effect on the corrosion properties of stainless steels.

Due to the electrochemical effects as described above, the “noble” stainless steel fastener induces a very low rate of corrosion of the “less noble” base material and fastened material, or possibly no corrosion at all. This behavior has also been confirmed in a number of salt spray tests and in long-term tests with exposure to sea water in the tidal zone on an island in the North Sea.

In all of these tests, no corrosion occurred. The condition of a specimen after seven years of sea water tests is shown in the photo on the left. No evidence of corrosion can be found at the anchoring zone of the X-BT fastener. The seal achieved has remained fully functional, no electrolyte is present and contact corrosion is not an issue.



Steel base material after 7 years of exposure to sea water and pull-out of the X-BT fastener. The hole appears clean and no evidence of corrosion is visible.

This summary is intended to be representative of the test(s) carried out. It is not intended to be a full and complete test report.

5.3.3 Corrosion data from field tests at Helgoland Island (North Sea)

Expert assessment: Investigation of the corrosion resistance of Hilti X-BT fasteners in marine atmospheres and in sea water,

9004742000 G/Bf; MPA, University of Stuttgart; Feb 3, 2014

Test material

| | |
|---------------------|---|
| Base material | S235 steel ($f_u = 439$ MPa), 8 mm thick |
| Number of specimens | 24 steel plates, each with 18 X-BT studs |

Test procedure

The test specimens were installed in May 2003 and samples taken periodically from each zone for assessment in June 2004, June 2005, May 2008 and April 2013.

Microscopic and metallurgical investigations to assess corrosion were carried out by MPA, University of Stuttgart. The tensile resistance tests were carried out by Hilti under supervision of the MPA.

Test results

Test specimens after 10 years of exposure to sea water in the tidal zone of the North Sea. No evidence of corrosion is visible on the X-BT studs and X-FCM discs. Only slight discoloration due to deposits can be observed on the X-FCM discs.

Conclusions

- After 10 years of exposure to sea water, no obvious signs of corrosion were found on the X-BT fasteners.
- After 10 years of exposure to sea water, no relevant signs of corrosion were found on the X-FCM fasteners.
- After 10 years of exposure to sea water, no corrosion was found in the drilled holes. This is strong evidence that the sealing washer provides an effective seal.
- Ultimate pull-out strength of the fasteners was not affected by the field tests. The pull-out load achieved in monitoring tests carried out in June 2003 was 8.6 kN, and in 2013 it was 10.3 kN.

Based on the long-term tests carried out by the MPA as described above, the University of Stuttgart [Expert Assessment, 9004742000 G/Bf Feb 3, 2014] came to the following conclusion:

From a corrosion-specific point of view, it can thus be assumed that the Hilti X-BT system will have a life of more than 40 years, even under atmospheric conditions (corrosion categories C4 respectively C5-M) of use where chloride is present (marine atmospheres and in the splash zone).

Steel base material after 10 years of exposure to sea water and pull-out of the X-BT fastener. The hole appears clean and no evidence of corrosion is visible.



- 8 specimens in an atmospheric testing rig in accordance with ISO 8565
- 16 specimens in a sea water testing rig, wave zone and tide zone, in accordance with ISO 11306



Marine atmosphere test rig with X-BT test specimens installed.



Sea water test rig with test specimens installed (X-BT with and without X-FCM grating discs).





5.4 Effect of X-BT threaded stud fastenings on steel base material

Experimental investigations on the effect of X-BT fasteners on the static strength of the base material structural steel

Report No. XE_02_07; Hermann Beck; 17 June 2002

Experimental investigations on the effect of X-BT fasteners on the fatigue strength of the base material structural steel

Report No. 2010-57X by Prof. U. Kuhlmann and H.P. Günther from the University of Stuttgart: Fatigue classification of the constructional detail "Structural steel base material with the Hilti powder-actuated fastener X-BT" in compliance with Eurocode 3 Part 1-9 (EN 1993-1-9), (2010)

Reports No. 453'150/1e, 453'150/2e, 453'150/3e, 455'377/e by EMPA,

Swiss Federal Laboratories for Materials Testing and Research (2010)

Report No. TWU-FSRL-13/09 by Hilti FSRL,

Fastening System Research Laboratories (2010).

| | |
|--------------------------------|---|
| Base material (static tests): | Steel, 8 and 10 mm, S235 and S355 |
| Base material (fatigue tests): | Steel, 8, 20 and 40 mm, S235, S355, S460M, S460G4+M |
| Number of fastenings in test: | 48 static tensile and 191 fatigue tests |

Load-deformation behavior of steel with X-BT fasteners

Evaluated in tensile tests performed with coupons with X-BT fasteners (XE_02_07)

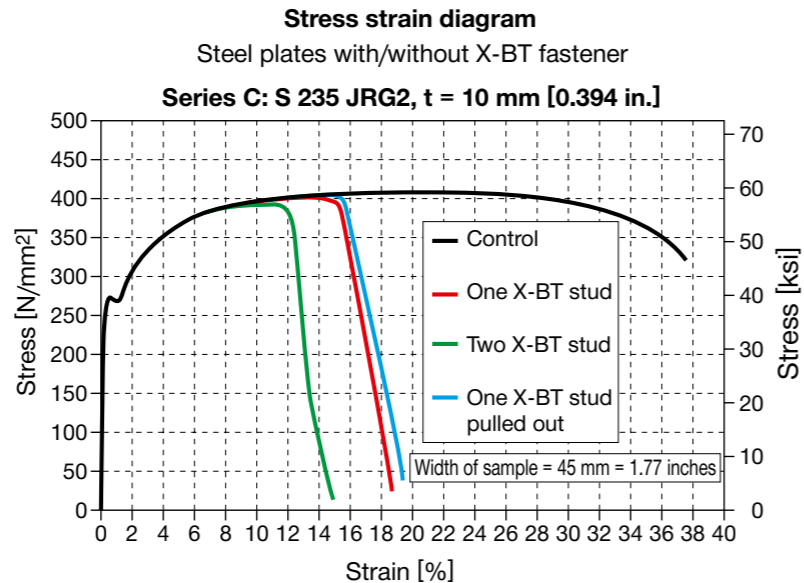

Conclusions

- The very high net section efficiencies observed with Hilti DX powder-actuated fasteners also develop for plates with X-BT fasteners.
- Generally, the presence of an X-BT fastener need not be taken into account in the design of tensile members made of structural steel.
- In case of exceptionally high fastener concentrations (net area < 92 % of gross area), application of the design provisions of AISC-LRFD or Eurocode 3 for drilled holes leads to conservative results.

This summary is intended to be representative of the test(s) carried out. It is not intended to be a full and complete test report.

5.4.1 Fatigue classification in compliance with Eurocode 3 (EN 1993-1-9). Structural steel base material with Hilti powder-actuated fastener X-BT

Hilti ran a comprehensive fatigue test program in order to classify the constructional detail "Structural steel base material with the Hilti powder-actuated fastener X-BT" in compliance with the Eurocode 3 (EN 1993-1-9, [4]). A corresponding evaluation was made by Prof. U. Kuhlmann and H.P. Günther from the University of Stuttgart (Report No. 2010-57X [3]).

| Detail category | Constructional detail | Description | Requirements |
|-----------------|-----------------------|---|--|
| 90 | | Hilti X-BT powder-actuated fasteners with pre-drilled hole in structural steel base material. Imperfect fastener installations as e.g. pulled-out fasteners or pre-drilled holes without fasteners are covered. | $\Delta\sigma$ to be calculated by the gross cross-section. Installation, static loading and spacing of fasteners only in accordance with the requirements of the Hilti X-BT threaded fastener specification. Plate thickness $t \geq 8$ mm Edge distance ≥ 15 mm |
| 100 m = 5 | | | |

Table 1. Recommendation of fatigue detail category according to EN 1993-1-9:2005 [3]

Category 90 corresponds with a standard category according to Table 7.1 of EN 1993-1-9 [4] with a slope $m = 3$ for cycles $N \leq 5$ million cycles and a slope $m = 5$ for $N > 5$ million cycles (see Figure 2). Category 100 ($m = 5$) - with a constant slope $m = 5$ for $N \leq 100$ million cycles - represents a possible, alternate option in compliance with the Eurocode 3. The latter is recommended in case of low amplitude high cycle fatigue loading. When using a fatigue assessment procedure based on a linear damage accumulation a mixture of both categories is not allowed.

The structural steel grades S235 up to S460 according to EN 10025-2, EN 10025-3, EN 10025-4 and EN 10225 are covered. These grades include thermo mechanically rolled fine grain steels.

The following Figure 1 shows a summary of all test data including the fatigue classification in keeping with the Eurocode 3.

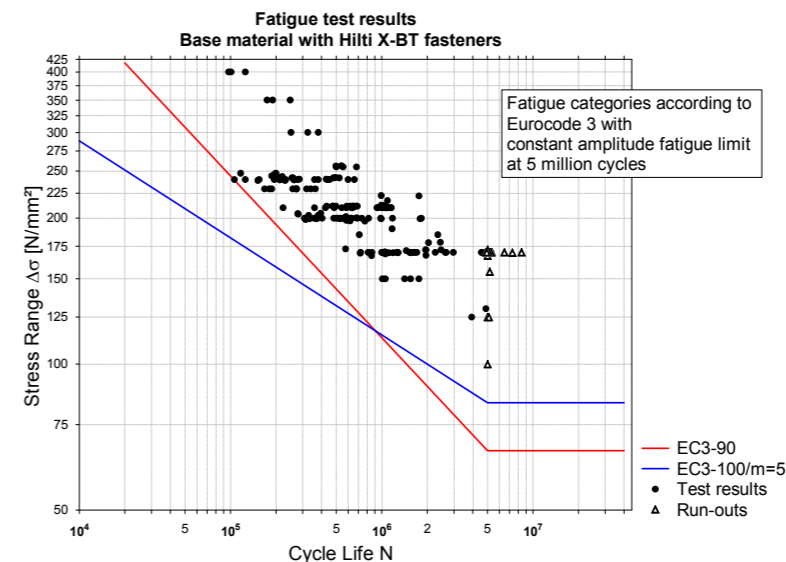

Figure 1. Test data compared with fatigue recommendation according to Eurocode 3 [3]

This summary is intended to be representative of the test(s) carried out. It is not intended to be a full and complete test report.

5.4.2 Approved fatigue categories by GL (Germanischer Lloyd) and DNV (Det Norske Veritas)

Towers for wind turbines as well as the machinery for the wind turbines often are approved by classification societies like GL (Germanischer Lloyd) or DNV (Det Norske Veritas). Both classification societies recently also approved the fatigue category for the constructional detail "Structural steel base material with Hilti powderactuated fastener X-BT", see Table 2.

| Classification Society | Hilti Type Approval Certificate | Fatigue standard | Detail category | Plate thickness | Thickness effect |
|------------------------|---------------------------------|-----------------------|-----------------|------------------|---------------------------|
| GL | 12272-10HH [1] | EC 3, EN 1993-1-9 [4] | 90 | 8 mm ≤ t ≤ 60 mm | No. k _s = 1 |
| DNV | S-6751 [2] | DNV RP-C203 [5] | C2 | t ≥ 8 mm | for t ≥ 25 mm k = 0.15 |

Table 2. Approved categories by GL and DNV

Notes on GL Type Approval:

In order to allow clear use of the design category, GL proposed only to use the standard category 90 and omit the alternative option 100 with m = 5. GL also limited the use to the thickness range typically used in steel towers of wind turbines (t ≤ 60 mm). In case thicker plates are exceptionally used, acceptance is possible based on case specific consideration.

Note on DNV Type Approval:

Differing from the provisions in EN 1993-1-9 [4], the DNV fatigue standard DNV-RP-C203 [5] requires the consideration of the size effect (coefficient k = 0.15) for the detail category independent from the constructional detail. Therefore, for compliant design with DNV-RP-C203 a thickness effect is considered for thickness t ≥ 25 mm.

The fatigue strength curves are mathematically described by the following formula:

$$\log N = \log \bar{a} - m \cdot \log \Delta\sigma$$

The parameters m and log \bar{a} of the fatigue curves are summarized in the following tables 3 & 4. Table 5 gives also a comparison of the stress ranges $\Delta\sigma$ for selected numbers of cycles and Figure 2 shows a graph with test data and the approved fatigue categories.

| Number of load cycles N | m | log \bar{a} |
|---|---|---------------|
| N ≤ 5.10 ⁶ | 3 | 12.164 |
| 5.10 ⁶ ≤ N ≤ 10 ⁸ | 5 | 15.807 |

Table 3. Parameters of GL approved fatigue curve 90 according to EN 1993-1-9

| Number of load cycles N | m | log \bar{a} |
|-------------------------|---|---------------|
| N ≤ 10 ⁷ | 3 | 12.301 |
| N > 10 ⁷ | 5 | 15.835 |

Table 4. Parameters of DNV approved fatigue curve C2 according to DNV-RP-C203

| Number of load cycles N | Stress range $\Delta\sigma$ [N/mm ²] | |
|-------------------------|--|--------|
| | GL EC3 - 90 | DNV C2 |
| 1.10 ⁵ | 244.3 | 271.4 |
| 1.10 ⁶ | 113.4 | 126.0 |
| 2.10 ⁶ | 90.0 | 100.0 |
| 5.10 ⁶ | 66.3 | 73.7 |
| 1.10 ⁷ | 57.7 | 58.5 |
| 1.10 ⁸ | 36.4* | 36.9 |

Table 5. Comparison of stress ranges

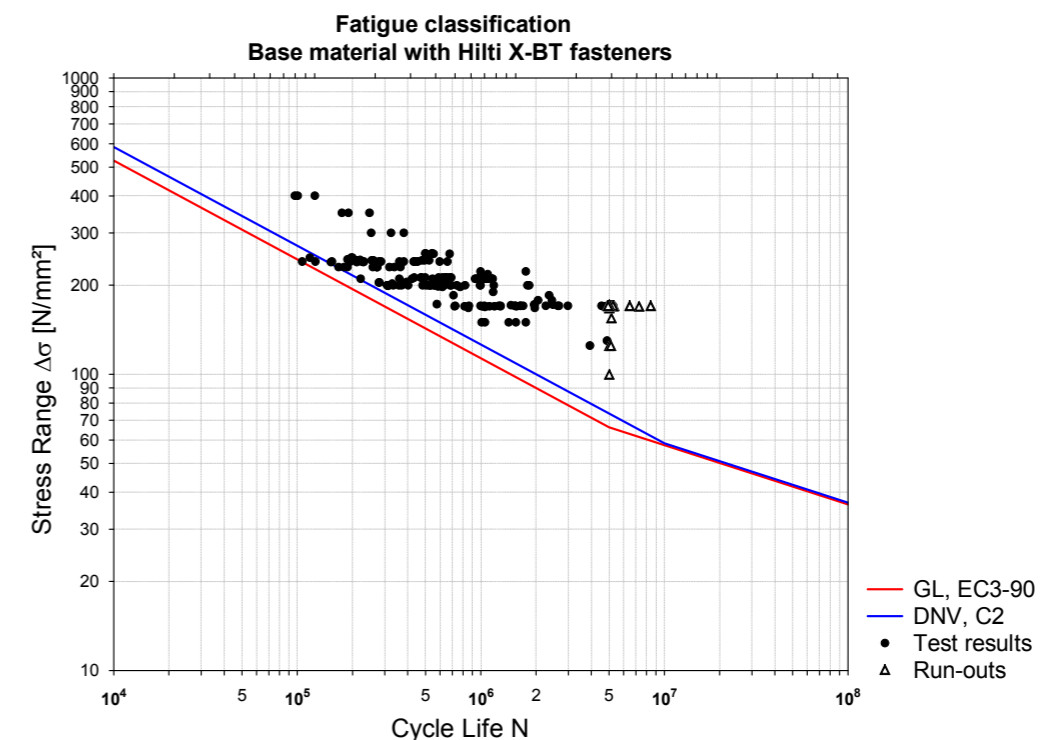

Figure 2. Test data compared with approved GL and DNV fatigue categories

Literature:

- [1] GL, Germanischer Lloyd (2011): Approval Certificate: 12272-10HH, Mechanical Fastening Systems, Hilti X-BT stainless steel threaded fasteners, Hamburg, 2011-11-04
- [2] DNV, Det Norske Veritas (2011): Type Approval Certificate No. S-6751, Structural Connecting Elements: X-BT threaded fasteners, Grating fasteners X-FCM-R, X-FCM-M, Høvik, 2011-10-26
- [3] Kuhlmann, U., Günther, H-P. (2010): Fatigue strength of the constructional detail "Structural steel base material with the Hilti powder-actuated fastener X-BT" in compliance with Eurocode 3 Part 1-9 (EN 1993-1-9), Institut für Konstruktion und Entwurf, Stahl- Holz- und Verbundbau, University of Stuttgart, Report Nr. 2010-57X, December 28, 2010
- [4] EN 1993-1-9:2005 (2005): Eurocode 3: Design of steel structures – Part 1-9: Fatigue, European Standard, May 2005
- [5] DNV-RP-C203, Det Norske Veritas (2010): Recommended Practice: Fatigue design of offshore steel structures, April 2010

5.5 Corrosion resistance

5.5.1 Cast iron specification

Components made from cast iron with spheroidal graphite are typically used in the nacelle of wind towers. The preferred grade is EN-GJS-400-18-LT according to EN 1563 with a minimum ultimate strength of 400 N/mm² (for thickness $t \leq 30$ mm), a minimum fracture strain A of 18 % and with impact toughness properties suitable for use in cold temperatures. The use of cast iron with spheroidal graphite allows economical production of complex machinery parts combined with ductile material behaviour.

The presence of spherical graphite is required to allow the casting process. Figure 3 shows a representative example of a micro section of cast iron EN-GJS-400-18-LT. The distribution of the spheroidal graphite in the ferritic matrix is clearly visible.

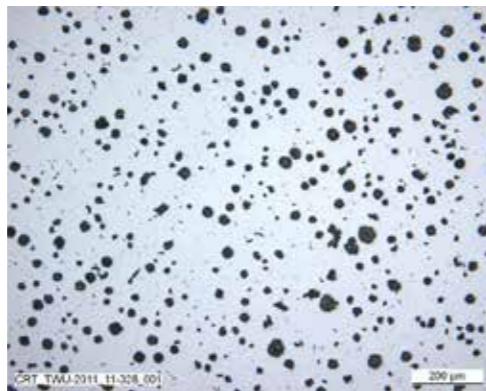

Figure 3. Micro section of cast iron EN-GJS-400-18LT: Spheroidal graphite embedded in ferritic matrix

The cast iron needs to meet the following specification given in Table 6. The listed carbon content and microstructure is typical for EN-GJS-400-18-LT used in the nacelle of wind towers.

| Subject | Requirements |
|--|---|
| Cast iron | Spheroidal graphite cast iron according to EN 1563 |
| Strength class | EN-GJS-400 to EN-GJS-600 according to EN 1563 |
| Chemical analysis and amount of carbon | 3.3 - 4.0 mass percentage |
| Microstructure | Form IV to VI (spherical) according to EN ISO 945-1:2010 Minimum size 7 according to Figure 4 of EN ISO 945-1:2010 |
| Material thickness | $t_{II} \geq 20$ mm |

Table 6. Requirements of spheroidal graphite cast iron base material

5.5.2 Grounding and bonding restrictions

No corresponding experimental investigations have been made so far. There, the use of X-BT-ER fasteners for grounding and bonding application is not covered, in case the fasteners are driven to cast iron components.

5.5.3 Performance review

In order to investigate the influence of cast iron base material on the performance of X-BT fasteners a comprehensive test program was run. The scope of the program included the following experimental investigations (summary and assessment in [1]):

- Static pullout tests
- Static shear and bending tests
- Tension fatigue tests
- Tests to cover the effect of the edge distance
- Tests to cover the effect of the cast iron surface

Compared with the performance of X-BT fasteners in unalloyed structural steel, the recommended load values are smaller due to the presence of the graphite in the cast iron. As with unalloyed structural steel, reliable anchorage of the X-BT fastener develops also in case of cast iron base material. The anchorage is also caused by predominantly friction welding between the fastener shank and the ferritic or perlitic matrix of the cast iron. However, the presence of the graphite reduces the effective contact area, which explains the reduction of the pullout strength.

Furthermore, the recommended loads cover implicitly effects of dynamic and variable loading on the fastener. This statement is based on the results of tension fatigue tests, which were performed to investigate the robustness of the anchorage of X-BT fasteners in cast iron, see Figure 4 and 5.

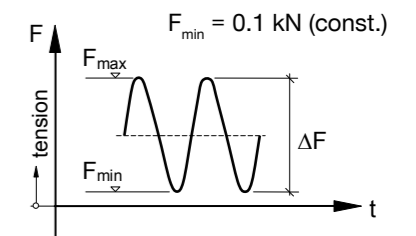
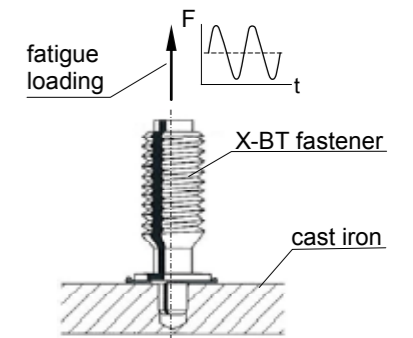

Figure 4. Principle sketch of cyclic tension tests



Figure 5. Servo-hydraulic test setup for tension fatigue tests

Conclusions from the cyclic tension tests:

- The anchorage of the X-BT does not work loose. In none of the tests pull-out of the fastener from the cast iron was the controlling mode of failure.
- Failure was controlled by fatigue fracture of the stainless stud material. The fractures occurred at upper loads significantly beyond the recommended tension load of 0.5 kN.
- For final verification and with respect to the reported design life of wind towers, two fatigue tests were performed with an upper load of 1.0 kN (which is double the recommended tension load) and a target number of 200 million load cycles.
- Both long run samples passed the test without any damage, neither to the fastener material nor to the anchorage. Residual static pullout tests of these two samples resulted in a pullout strength beyond 5 kN.
- The test results clearly verify reliable X-BT fastenings to cast iron EN-GJS-400-18LT used in the nacelle of wind towers.

Figure 6. shows a graph of the fatigue test results performed with X-BT fasteners. The load-level of the runouts is by far beyond the recommended working load of 0.5 kN, especially see the two run-outs at 200 million load cycles with an upper load of 1.0 kN.

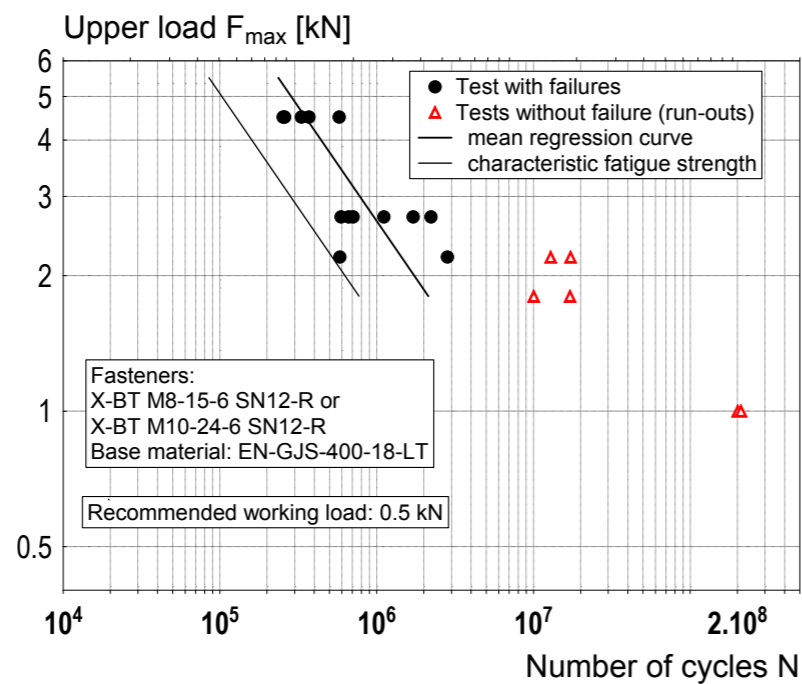

Figure 6. Results of cyclic tension tests

Literature:

- [1] Kuhlmann, U., Günther, H-P. (2011): Hilti powder-actuated fastener X-BT in combination with the Hilti fastening tools DX 351 BT/BTG for the use in cast iron base material according to EN 1563, Evaluation Report, Institut für Konstruktion und Entwurf, Stahl- Holz- und Verbundbau, University of Stuttgart, Report Nr. 2011-24X, Oct. 11, 2011.

This summary is intended to be representative of the test(s) carried out. It is not intended to be a full and complete test report.

5.6 Vibration effects on X-BT threaded stud fastenings

Experimental investigations on the effect of base metal vibrations on the ultimate pull-out

Report No. XE_02_09; Hermann Beck; 19 June 2002

| | |
|-----------------------|--|
| Base material | Steel, S235 |
| Beam section | HE-A section, 9 mm flange, 6 mm web |
| Test procedure: | Beam loaded in the center F _{max} = 155 kN, F _{min} = 33 kN Frequency = 6 Hz Number of cycles = 2 Million |
| Number of fastenings: | 210 X-BT fasteners, some with X-FCM-R grating disks |

Ultimate pull-out of X-BT fasteners before and after cyclic loading of the steel beam

X-BT fasteners in area without grating

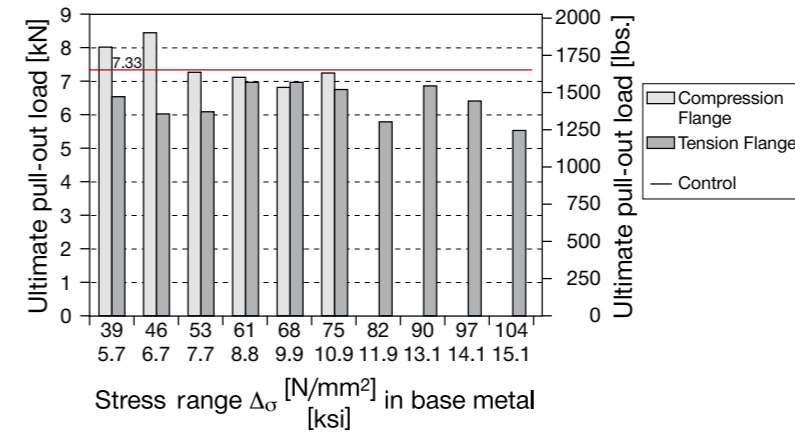

X-BT fasteners in area with grating

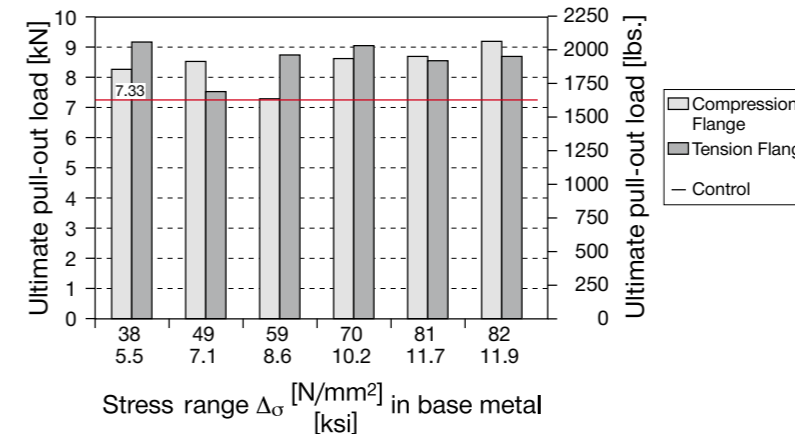

Conclusions

- Cyclic loading applied to steel beams, which causes vibration on the fastener, has only a negligible effect on the ultimate pull-out of X-BT threaded studs
- Cyclic loading applied to steel beams, which causes vibration on the fastener, does not result in loosening of grating X-FCM-R grating disks

This summary is intended to be representative of the test(s) carried out. It is not intended to be a full and complete test report.

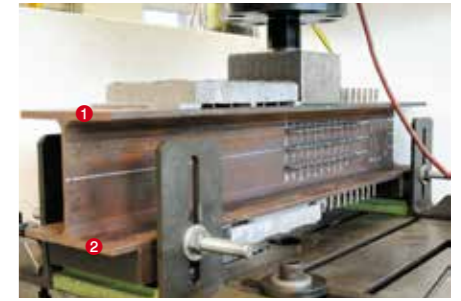

- 1 Compression flange
- 2 Tension flange

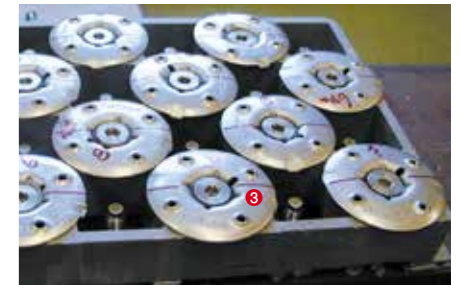

- 3 Markings to measure disc rotation

7.33 kN = Ultimate pull-out on the sample before stress was applied (control). No measurements taken on the compression flange in the high stress area due to position of the press.

7.33 kN = Ultimate pull-out on the sample before stress was applied (control).

5.7 Temperature resistance of X-BT threaded stud fastenings

Direct Fastening Technology Manual, Edition 11/2009
 Report No. XE_07_78; R. Buhri, December 2007

The temperature resistance of the Hilti X-BT fastening system is controlled by

- the temperature resistance of the stud
- the resistance of the X-BT stud anchorage in steel base material
- the effect of temperature on the corrosion resistance of the stud
- the temperature resistance of the SN12-R sealing washer

Temperature resistance of the X-BT stud material

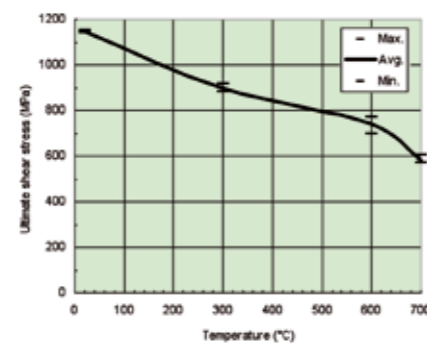

Tests at Swiss Federal Laboratory for Material Testing (EMPA)

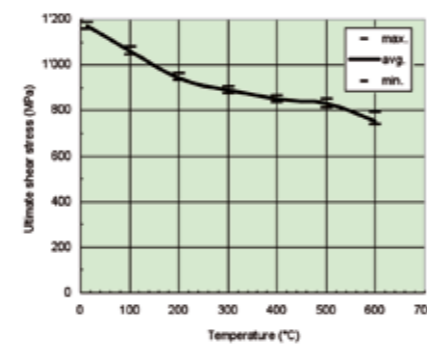

Tests at JTICM Laboratory Japan

At 600°C, the X-BT material has about 64% of its 20°C strength left. By comparison, structural steel has only about 26%.
 With a minimum tensile strength of $f_u = 1850 \text{ N/mm}^2$ the ultimate tensile resistance of the X-BT stud at 600°C is about 18.8 kN.

Temperature resistance of the X-BT stud anchorage in steel

| Steel base material: | Grade | Thickness [mm] | Strength Rm [MPa] |
|----------------------|-------|----------------|-------------------|
| | S 235 | 8 | 455 |
| | EH 36 | 8 | 536 |

Pull-out test configuration

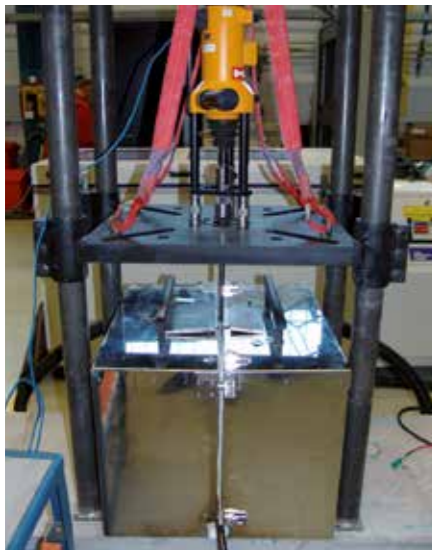

Tension cylinder on the furnace



X-BT on 8.0 mm base plate



Open furnace chamber

This summary is intended to be representative of the test(s) carried out. It is not intended to be a full and complete test report.

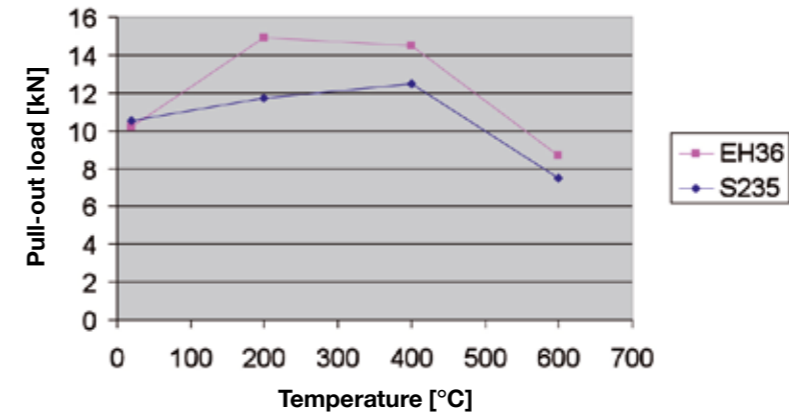

At 600°C, the pull-out resistance of the X-BT has about 71% of its 20°C strength left in steel S235 and about 85% in steel EH36.

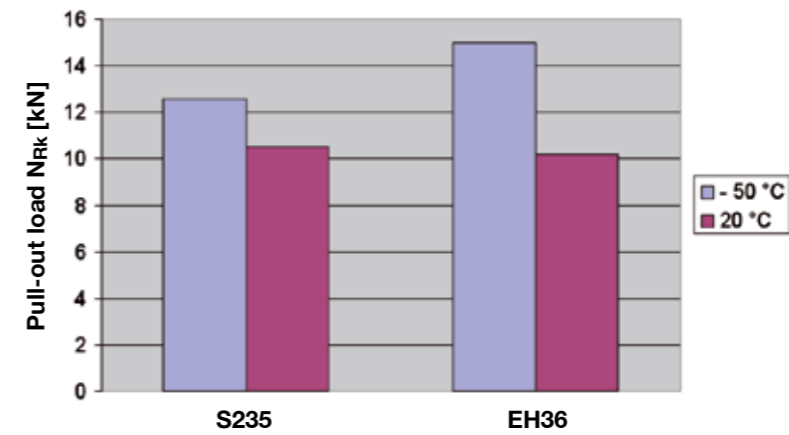

At low temperature the pull-out resistance is increasing compared to that at room temperature.

Conclusions

- The strength of the X-BT stud and its anchorage in steel base material does not control the limits of the system under extreme ambient temperatures.
- The corrosion resistance of the X-BT stud is verified up to +300°C
- The sealing function of the SN12-R sealing washer is verified for a temperature range of -40°C to +100°C

This summary is intended to be representative of the test(s) carried out. It is not intended to be a full and complete test report.

5.8 X-BT-ER stainless steel threaded studs electrical performances

Fasteners

X-BT-ER M10/3 SN 4
X-BT-ER W10/3 SN 4

X-BT-ER M8/7 SN 4

X-BT-ER M6/7 SN 4
X-BT-ER W6/7 SN 4

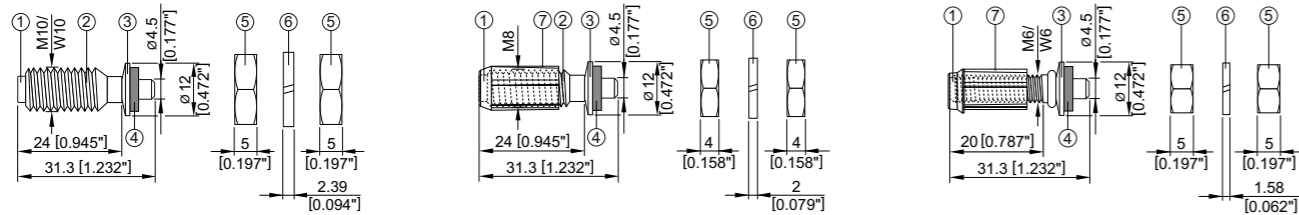

Test Report No. 09-IK-0208.32V2_e; Electrosuisse, Fehraltorf, Switzerland; May 2010
 Test Report No. CF-791; Dehn und Söhne GmbH, Neumarkt, Germany; March 2006
 Test Report No. 70064671; TÜV Test Centre, Frankfurt, Germany; March 2004
 Test Report No. 09-IK-0208: Suitability of Hilti X-BT-ER threaded studs as connection point in protective grounding and earthing circuits and for lighting protection; Electro-suisse, 2015

5.8.1 Permanent current

For low permanent current due to static charge built up in pipes or for low permanent current when closing an electrical circuit.

| | |
|----------------------|---|
| Test standard | IEC EN 60204-1:2006 |
| Test criteria | <p>The temperature of the fastening point should not exceed the limits of the cable under permanent current, e.g. 70°C (environmental temp at 40°C), for PVC cables. Test duration: Till temperature stability is reached.</p> |

| Tested configuration | Tested fasteners | Test results | | |
|-----------------------------|--------------------|--------------|-------------------|-------------|
| | | Current | Max. temp (in° C) | Result |
| Single point connection | X-BT-ER M10/3 SN 4 | 22 A | 32.0° C | pass |
| | X-BT-ER W10/3 SN 4 | | | |
| | X-BT-ER M8/7 SN 4 | 32 A | 39.1° C | pass |
| | X-BT-ER M6/7 SN 4 | | | |
| X-BT-ER W6/7 SN 4 | 60 A | 78.8° C | failed | |

Note: At 60 A, which is deduced from a protective grounding cable with cross section of 16 mm² (EN 60204-1; Tab 6), the maximally permissible temperature for PVC cables was exceeded for the connection. The maximum temperature permissible under normal condition is 70°C.

This summary is intended to be representative of the test(s) carried out. It is not intended to be a full and complete test report.

Conclusions

| Based on permanent current withstand ability | | | |
|--|-------------------|--------------------------|--|
| Current (max.) | Max. temp (in° C) | Connection configuration | Note: If the fastener is used in an environment and with cables which are heat resistant up to at least 90°C, then permanent currents up to 60 A can be applied. |
| 40A | 48.9° C | Single point connection | |

or

| Based on wire sizes as per EN 60204-1:1997 | | | |
|--|---------|--------------------------|---|
| Wire size (max.) | Current | Connection configuration | Note: If the fastener is used in an environment and with cables which are heat resistant up to at least 90°C, then wire sizes up to 16 mm ² can be used. |
| 10 mm ² (8 AWG) | 40A | Single point connection | |

This summary is intended to be representative of the test(s) carried out. It is not intended to be a full and complete test report.

5.8.2 Short circuit current

For discharging short circuit current while protecting electrical equipment or earth / ground or bonded cable trays and ladders

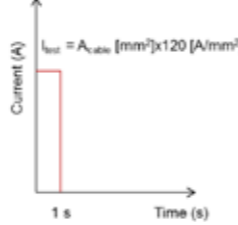
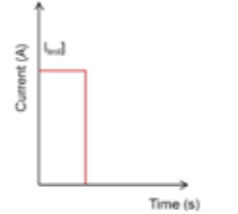
| Test standards | Requirements or test criteria |
|------------------|--|
| IEC 61000-5-2 | <ul style="list-style-type: none"> Tight contact between bonding strap terminal and equipment frame due to low electrical impedance Durably resistant to vibration Durably resistant to corrosion Durably resistant to mechanical forces and pull out forces Short time current withstand ability in accordance to IEC EN 60947-7-2 <p style="text-align: center;">pass</p> |
| IEC EN 60947-7-2 | <p>A grounding connection must be capable of withstanding a high test current (I_{test}) for an exposure time of 1 second.</p> <p>$I_{test} = A_{cable} [mm^2] \times 120 [A/mm^2]$ where A_{cable} = cross sectional area of the attached cable, exposure time 1 second</p> <p>i.e for wire size 10 mm², a current of 1200 A for 1 sec</p>  |
| UL 467 | <ul style="list-style-type: none"> TA grounding connection must be capable of withstanding a high test current (I_{test}) for a specified exposure time. <p>Table 14.1, e.g.</p> <ul style="list-style-type: none"> 14 AWG(2.1mm²) 300A for 4s 12 AWG(3.3mm²) 470A for 4s 10 AWG(5.3mm²) 750A for 4s 8 AWG(8.4mm²) 1180A for 4s  |

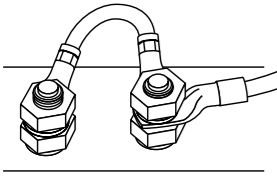
| Tested configuration | Tested fasteners | Test results | | |
|---|---|--|---------------|--------|
| | | Current | Exposure time | Result |
|  Single point connection | X-BT-ER M10/3 SN 4 X-BT-ER W10/3 SN 4 X-BT-ER M8/7 SN 4 X-BT-ER M6/7 SN 4 X-BT-ER W6/7 SN 4 | 1400 A (IEC) | 1 s | pass |
| | | 750 A (UL) | 4 s | rated |
| | | Note: Higher currents for a longer exposure time will result in failed connection. | | |
|  Double point connection | X-BT-ER M8/7 SN 4 X-BT-ER M6/7 SN 4 X-BT-ER W6/7 SN 4 | 2240 A (IEC) | 1 s | pass |
| | | Note: Higher currents for an exposure time of 1 s will result in failed connection | | |

This summary is intended to be representative of the test(s) carried out. It is not intended to be a full and complete test report. For complete test details, please contact Hilti.

Conclusions

Based on short term current withstand ability (irrespective of wire size)

| Current (max.) | Fastener | Exposure time | Connection configuration |
|----------------|---|---------------|--------------------------|
| 1400 A | X-BT-ER M10/3 SN 4 X-BT-ER W10/3 SN 4 | 1 s | Single point connection |
| 750 A | X-BT-ER M8/7 SN 4 X-BT-ER M6/7 SN 4 X-BT-ER W6/7 SN 4 | 4 s | |
| 2240 A | X-BT-ER M8/7 SN 4 X-BT-ER M6/7 SN 4 X-BT-ER W6/7 SN 4 | 1 s | Double point connection |

or

Based on wire sizes as per IEC 60947-7-2 & UL 467 (irrespective of current withstand ability)

| Wire size (Max.) | Fastener | Connection configuration |
|---|---|--------------------------|
| 10 mm ² (IEC) 10 AWG (UL) | X-BT-ER M10/3 SN 4 X-BT-ER W10/3 SN 4 X-BT-ER M8/7 SN 4 X-BT-ER M6/7 SN 4 X-BT-ER W6/7 SN 4 | Single point connection |
| 16 mm ² (IEC) | X-BT-ER M8/7 SN 4 X-BT-ER M6/7 SN 4 X-BT-ER W6/7 SN 4 | Double point connection |

This summary is intended to be representative of the test(s) carried out. It is not intended to be a full and complete test report. For complete test details, please contact Hilti.

5.8.3 Lightning current

For high temporary current due to lightning.

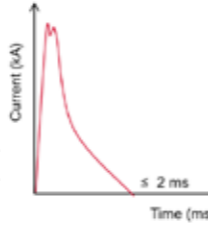
| Test standard | Test criteria |
|--|---|
| IEC 60060-1: 1999 "Lightning protection components Part 1: Requirements for connection components" and EN 50164-1 / prA1:2005 | Electrical test with stress of 3 times 50 or 100 kA (signal form 10/350 μ s) lightning current as follows: <ul style="list-style-type: none"> class H $I_{max} = 100 \text{ kA} \pm 10 \% W/R = 2,5 \text{ MJ}/\Omega \pm 20 \% t_d \leq 2 \text{ ms}$. class N $I_{max} = 50 \text{ kA} \pm 10 \% W/R = 0,63 \text{ MJ}/\Omega \pm 20 \% t_d \leq 2 \text{ ms}$.  |

| Tested configuration | Tested fasteners | Test results | | | |
|---|---|--|---------------|--------------------|-------------|
| | | Current | Exposure time | Contact resistance | Result |
|  Single point connection | X-BT-ER M10/3 SN 4 X-BT-ER W10/3 SN 4 X-BT-ER M8/7 SN 4 X-BT-ER M6/7 SN 4 X-BT-ER W6/7 SN 4 | 50 kA | 2 ms | < 2,5 m Ω | pass |
| | | Note: Higher currents for an exposure time of 2 ms will result in failed lightning connection. | | | |

In this connection configuration, the X-BT-ER is used as a fastener and not as an electrical conductor. The cable lug must be in direct contact with non-coated base material. Please refer to requirements in **2.6.3**.

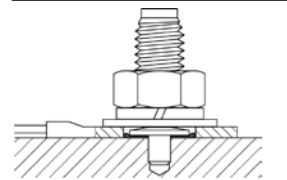
| Tested configuration | Tested fasteners | Test results | | | |
|---|---|--|---------------|--------------------|-------------|
| | | Current | Exposure time | Contact resistance | Result |
|  Single point connection | X-BT-ER M10/3 SN 4 X-BT-ER W10/3 SN 4 X-BT-ER M8/7 SN 4 | 100 kA | 2 ms | < 2,5 m Ω | pass |
| | | Note: Higher currents for an exposure time of 2 ms will result in failed lightning connection. | | | |

Conclusions

| Based on EN 50164-1:1999 and EN 50164-1 / prA1:2005 | | | |
|---|---------------|---|--|
| Current (max.) | Exposure time | Fastener | Connection configuration |
| 50 kA | 2 ms | X-BT-ER M10/3 SN 4 X-BT-ER W10/3 SN 4 X-BT-ER M8/7 SN 4 X-BT-ER M6/7 SN 4 X-BT-ER W6/7 SN 4 |  Single point connection |

In this connection configuration, the X-BT-ER is used as a fastener and not as an electrical conductor. The cable lug must be in direct contact with non-coated base material. Please refer to requirements in **2.6.3**.

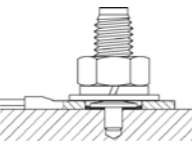
| Based on EN 50164-1:1999 and EN 50164-1 / prA1:2005 | | | |
|---|---------------|---|--|
| Current (max.) | Exposure time | Fastener | Connection configuration |
| 100 kA | 2 ms | X-BT-ER M10/3 SN 4 X-BT-ER W10/3 SN 4 X-BT-ER M8/7 SN 4 |  Single point connection |

This summary is intended to be representative of the test(s) carried out. It is not intended to be a full and complete test report.

5.9 X-BT in stainless steel base material

Hilti internal report XE_07_26; Reinhard Buhri, 21.05.2007

Stainless steel is very hard, so the drilling technique differs from that used for structural steel, the material for which the X-BT system has been optimized. Driving the X-BT stud in stainless steel presents no problem, but drilling is decisive.

Test material and conditions

| | |
|-----------------------------------|---|
| Type of drill bit: | Standard TX-BT 4/7 step shank drill bit Two special shank drill bits for stainless steel |
| Type of stainless steel material: | Material number: 1.4401, 1.4462, 1.4529, 1.4539 |
| Drilling procedure: | Wet or dry |
| Number of tests: | 495 drilling operations with 28 drill bits |
| Condition: | Hand held operation, same as the standard operation |

Results

- With all of the stainless steel materials tested, the standard TX-BT 4/7 drill bit was found to perform better than special drill bits.
- Cooling the drill bit does not lead to better results.
- Use of a corded electric drill is recommended due to the longer drilling time.
- Best results are achieved with a corded drill set to a speed of 1,000 r.p.m.
- To achieve satisfactory drilling performance, much higher pressure must be applied to the drill bit.
- About 25 to 35 holes can be drilled with a TX-BT 4/7 drill bit.
- Characteristic pull-out loads are in the 8 to 16 kN range, which provides an adequate safety factor for the recommended loads.

Recommendation

For making fastenings in stainless steel with Hilti X-BT studs we recommend use of the standard TX-BT 4/7 drill bit with a corded electric drill (not a cordless tool) set to a speed of 1,000 r.p.m. The following models are suitable:

- Hilti SR 16
- Hilti UH 650

This summary is intended to be representative of the test(s) carried out. It is not intended to be a full and complete test report.



Test configuration: Two base plates were populated with MQ channel fastened with X-BT studs. The base plates were rigidly attached to the 2-tonne shock loading machine.

5.10 X-BT under shock loading

Shock tests with X-BT studs and MQ channel systems for fastening electrical cable and pipe runs are described in these documents:

Test certificate number QUINETIQ/CMS/TC040089;
QinetiQ Shock Test Laboratory, 15.01.2004
Report 2004-CMC-R017, TNO Delft, Netherlands, 29.05.2005

Mechanical and electrical equipment fastened with MQ channels and X-BT studs tested under shock load.

- Small-bore pipe runs
- High-voltage cable runs
- T-bars for fastening high-voltage cables
- Cable basket electrical runs
- Cable tray electrical runs

All applications were tested with an effective acceleration of 1844 m/s² in the three orthogonal axes, in horizontal (longitudinal and side to side) and vertical direction. In another test, X-BT studs with a mass of 3 kg each were installed on a shock test rig and tested with a maximum effective acceleration of 4905m/s².

Test results

- The channel system, the X-BT studs and the attached equipment remained captive at all times.
- The tested effective acceleration of 1844 m/s² corresponds to a shock load of 188 g.
- The X-BT with a fastened mass of 3 kg withstood a shock load of 200 G in horizontal (shear) and 500 G in longitudinal (tension) direction.

Lightweight high impact shock testing of Hilti X-BT studs for electrical cable holder, electrical box and slotted channel installations are also described in HI-TEST LABORATORIES, INC., Report No. 1475, April 30, 2007.

X-BT stud fastened assemblies were subjected to lightweight high impact shock tests in accordance with MIL-S-901D(NAVY) and HI-TEST Procedure No. HT-1780-TP-1, Revision “-”.

Testing was conducted at HI-TEST LABORATORIES, INC., Arvonia, Virginia, using their standard Navy shock testing machine for lightweight equipment.

HI-TEST LABORATORIES, INC. is approved for class H.I. (High Impact) shock testing by NAVSEA per NAVSEAINST 9491.1C dated 21 March 1996. Nine blows were applied to each test item - three blows in each of the three mutually perpendicular axes of the test item (from the top, back, and side) at hammer heights of 1, 3, and 5 feet. Two separate lightweight shock tests were performed, one for each test panel. Shock test accelerations ranged from - 80 to 300 G's.

Test Results

There was no evidence of broken or loose parts during the test series. There was also no evidence of damage to the test cables that could be considered an electrical hazard.

This summary is intended to be representative of the test(s) carried out. It is not intended to be a full and complete test report.

5.11 X-BT stud in steel with a thickness of less than 8 mm

5.11.1 Pull-out capacity in thin steel

Load behavior on special steel structures,

Report XE_01_57; R. Buhri; 30. 11. 2001

Pull-out strength of blunt-tip stainless steel threaded studs,

Report XE_02_23; R. Buhri; 9.4.2002

The characteristic pull-out resistance of X-BT threaded studs is a bi-linear function of base steel thickness as shown in section 6.2.2. A linear function can be derived from this graph for calculation of the reduction factor for the resistance of X-BT fastenings on steel with a thickness of less than 8 mm.

Reduction factor: $\alpha = \frac{t_{II} - 2}{6}$; with t_{II} := thickness of base steel
4 mm ≤ t_{II} ≤ 8 mm

Section 6.2.2 also shows a graph for the pull-out load as a function of base steel ultimate tensile strength. The reduced loads for different steel grades can be calculated on this basis:

| | |
|---------------------------------|---|
| A) reduced characteristic load: | $N_{Rk,red} = 6.0 \text{ kN} \cdot \alpha$ for steel S235 (A36) |
| | $N_{Rk,red} = 7.6 \text{ kN} \cdot \alpha$ for steel S355 (A572 grade 50) |
| B) reduced recommended load: | $N_{rec,red} = N_{rec} \cdot \alpha$ for steel S235 (A36) |

Example

For a base steel thickness of 6 mm, the recommended loads using Hilti global safety factors are:

| | |
|------------------------|--|
| Steel S235 / ASTM A36: | $N_{rec,6} = 1.8 \cdot (6-2)/6 = 1.2 \text{ kN}$ |
| Steel S355 / grade 50: | $N_{rec,6} = 2.3 \cdot (6-2)/6 = 1.5 \text{ kN}$ |

5.11.2 Shear load capacity in thin steel

- Tensile and shear strength in thin steel, Report XE-02-39, R. Buhri; 16.7.2002
- Bearing capacity in steel with a thickness of 4 to 6 mm, Report XE-02-68; R. Buhri; 31.10.2002
- Shear strength of blunt-tip stainless steel threaded studs, Report XE-01-45; R. Buhri; 10.10.2001
- ABS witnessed tests # MF 349780

A comparison of shear test data for 6 mm, 8 mm, 10 mm and 20 mm steel thicknesses has shown that base material thickness has no influence on the bearing capacity of the X-BT stud. The failure mode and test results shown below lead to the conclusion that this also applies to thin steel material with $t_{II} = 4.5$ mm, which is the mean embedment depth of the X-BT.

This summary is intended to be representative of the test(s) carried out. It is not intended to be a full and complete test report.

X-BT shear loads on steel S235

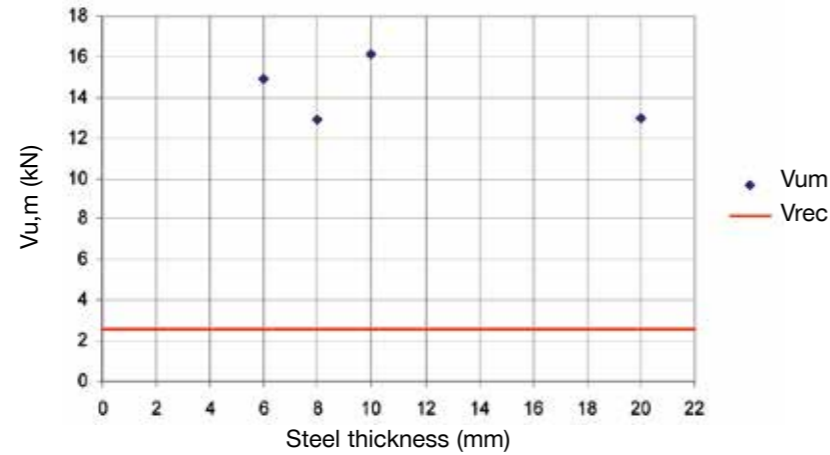

Under pure shear loads, the failure mode of X-BT studs is yielding of the steel base material as well as yielding of the stud itself, as shown in the following illustrations:



Plastic deformation of base steel



Plastic deformation of X-BT

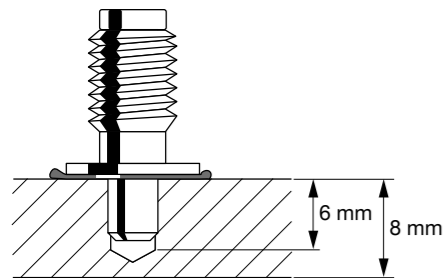

5.11.3 X-BT-ER electrical conductivity in thin steel

Reduction of the base material thickness to 6 mm will result in the same contact area between the shank of the stud and the base material as with 8 mm material (see drawing). The embedment depth of the stud is within the 4.5 to 5.6 mm range.

Due to this, a reduction in electrical conductivity in 6 mm base steel is not expected because the main parameter for electrical conductivity is the contact area between base steel and the X-BT-ER stud.

It must be noted that no electrical conductivity tests have been carried out for base steel with a thickness of less than 8 mm. The above statement is based on an engineering judgment only.

General note

With a base steel thickness of less than 8 mm, it can no longer be ensured that corrosion protection on the reverse side of the steel plate remains intact.

This summary is intended to be representative of the test(s) carried out. It is not intended to be a full and complete test report.

5.12 Chemical resistance of SN 12 sealing washer

(X-BT sealing washer)

| Chemicals | Volum swell | | | | | |
|---|-------------|--------|---------|--------|----------|-------|
| | <20% | 20-40% | >40-60% | 60-80% | >80-100% | >100% |
| 1. Water at 80°C | ■ | | | | | |
| 2. Sea water | ■ | | | | | |
| 3. Zinc chloride 10% | ■ | | | | | |
| 4. Sodium chloride 15% | ■ | | | | | |
| 5. Hydrochloric acid 10% | ■ | | | | | |
| 6. Acetic acid | ■ | | | | | |
| 7. Acrylonitrile | | | | ■ | | |
| 8. Aniline | | | | ■ | | |
| 9. n-Butyl acetate | | | | | ■ | |
| 10. Diethylether | | ■ | | | | |
| 11. Ethanol | ■ | | | | | |
| 12. Glycerol | ■ | | | | | |
| 13. n-Hexane | ■ | | | | | |
| 14. Methanol | ■ | | | | | |
| 15. Methyleneethylketone | | | | ■ | | |
| 16. Nitrobenzene | | | | ■ | | |
| 17. 1-Propanol | ■ | | | | | |
| 18. Oil (ASTM-1) at 80°C | ■ | | | | | |
| 19. Oil (ASTM-2) at 80°C | | ■ | | | | |
| 20. Oil (ASTM-3) at 80°C | | ■ | | | | |
| 21. Reference fuel B (isooctane/toluene, 70/30) | | | | ■ | | |
| 22. Reference fuel C (isooctane/toluene, 50/50) | | | | | ■ | |
| 23. Hydraulic brake fluid | ■ | | | | | |
| 24. Hydraulic brake fluid at 100°C | | ■ | | | | |
| 25. Antifreeze (ethylene glycol/water 50/50) at 125°C | | ■ | | | | |

Material: 3.1107 Elastomer: CR ozone and UV resistance Temperature range: -40°C to +100°C

Volume swelling is a reaction of the material of the washer when it's in contact with the different substances. It's used as a parameter to describe the chemical reaction.

The swelling factor gives an indication of the behavior of the material, but swelling does not lead directly to loss of the sealing property. With an installed stud, the washer is compressed against the base steel.

Without any specific requirement it can be stated that the washer is resistant to all substances where the volume swelling value is not above 20 to 40%.

This summary is intended to be representative of the test(s) carried out. It is not intended to be a full and complete test report.

5.13 Material safety data sheet for SN12 sealing washer acc. to ISO/DIS 11014

5.13.1 Identification of substance

Product details

Trade name: Plate 2.0x650x50.000 mm OE 3.1107

Application of the substance / the preparation: Rubber compound

Manufacturer/supplier:

PHOENIX CBS GmbH, Hannoversche Straße 88, D-21079 Hamburg

Information department:

Conseo GmbH Abteilung Umweltschutz, Hannoversche Straße 88

D-21079 Hamburg, 040 32809 2794

Emergency information:





0049(0)40 7667 2233

5.13.2 Composition/data on components

Chemical characterization

Description: Mixture of the substances listed below with non-hazardous additions

Dangerous components

| | | | |
|------------|-----------------------------|---|---------|
| 117-81-7 | bis(2-ethylhexyl) phthalate |  T; R 60-61 | 2.5-10% |
| 1309-48-4 | magnesium oxide | | 2.5-10% |
| 1314-13-2 | zinc oxide | | 2.5-10% |
| 68953-84-4 | N,N'-Diaryl-p-phenyldiamine |  Xi,  N; R 43-50/53 | ≤ 1.0% |
| 97-39-2 | 1,3-di-o-tolylguanidine |  T; R 25 | ≤ 1.0% |

Additional information: For the wording of the listed risk phrases refer to section 16.

5.13.3 Hazards identification

Hazard description **U**

Information pertaining to particular dangers for man and environment:

The product has been classified in accordance with EU directives / national laws respectively. In the version marketed, it presents no risk to the environment or to health. Following directive 67 / 54 8 EC, annex VI, point 9.3 it is not necessary to be labelled.

Classification system

The classification was made according to the latest editions of international substances lists and expanded upon from company and literature data.

NFPA ratings (scale 0 - 4)

Health = 0, Fire = 0, Reactivity = 0



HMIS-ratings (scale 0-4)

Health = *0, Fire = 0, Reactivity = 0

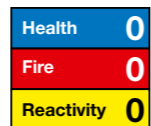

5.13.4 First aid measures

General information: No special measures required.

After inhalation: Supply fresh air; consult doctor in case of complaints.

After skin contact: Generally the product does not irritate the skin.

After eye contact: Rinse opened eye for several minutes under running water.

After swallowing: If symptoms persist consult doctor.

5.13.5 Fire fighting measures

Suitable extinguishing agents:

CO₂, extinguishing powder or water spray. Fight larger fires with water spray or alcohol resistant foam.

Special hazards caused by the material, its products of combustion or resulting gases:

Formation of toxic gases is possible during heating or in case of fire.

In case of fire, the following can be released:

Carbon monoxide (CO), Sulphur dioxide (SO₂), Hydrogen chloride (HCl)

Protective equipment: No special measures required.

5.13.6 Accidental release measures

Person-related safety precautions: Not required.

Measures for environmental protection: No special measures required.

Measures for cleaning/collecting: Pick up mechanically.

Additional information: No dangerous substances are released.

5.13.7 Handling and storage

Handling

Information for safe handling: No special measures required.

Information about protection against explosions and fires:

No special measures required.

Storage

Requirements to be met by storerooms and receptacles:

No special requirements.

Information about storage in one common storage facility: Not required.

Further information about storage conditions: None.

5.13.8 Exposure controls and personal protection

Additional information about design of technical systems:

No further data; see item 7.

Components with limit values that require monitoring at the workplace:

When working with the product N-nitrosamines can be liberated

117-81-7 bis(2-ethylhexyl) phthalate

| | |
|-----|--|
| PEL | 5 mg/m ³ |
| REL | Short-term value: 10 mg/m ³ Long-term value: 5 mg/m ³ |
| TLV | 5 mg/m ³ |

1309-48-4 magnesium oxide

| | |
|-----|-------------------------------|
| PEL | 15* mg/m ³ fume |
| TLV | 10 mg/m ³ fume |

1314-13-2 zinc oxide

| | |
|-----|--|
| PEL | 15*; 5** mg/m ³ Dust only *Total dust **Respirable dust |
| REL | Short-term value: C 15*; 10** mg/m ³ Long-term value: 5, 5** mg/m ³ Zinc oxide, Dust only; *15-min Dust only; **Zinc |
| TLV | Short-term value: 10** mg/m ³ Long-term value: 10* 5** mg/m ³ *dust **fume; *NIC-2 R; *10 R; *(e) |

Additional information

The lists that were valid during formulation were used as a basis.

Personal protective equipment

General protective and hygienic measures:

The usual precautionary measures for handling chemicals should be followed.

Protection of hands

The glove material must be impermeable and resistant to the product / the substance / the preparation.

As no test information is available, no recommendation about glove material can be given for the product/ the preparation/ the chemical mixture.

Selection of the glove material on consideration of the penetration times, rates of diffusion and the degradation.

Glove material

Selection of suitable gloves does not only depend on the material, but also on further marks of quality and varies from manufacturer to manufacturer. As the product is a preparation of several substances, the resistance of the glove material can not be calculated in advance and must therefore be checked prior to the application.

Penetration time of glove material

The exact breakthrough time must be stated by the manufacturer of the protective gloves and must be observed.

Eye protection

Not required.

5.13.9 Physical and chemical properties

General Information

| | |
|--------|------------------------------------|
| Form: | Solid |
| Color: | According to product specification |
| Odor: | Characteristic |

Change in condition

| | |
|------------------------------|---|
| Melting point/melting range: | Undetermined. |
| Boiling point/boiling range: | Undetermined. |
| Flash point: | Not applicable. |
| Ignition temperature: | 370.0°C (698°F) |
| Auto igniting: | Product is not self-igniting. |
| Danger of explosion: | Product does not present an explosion hazard. |
| Density at 20°C (68°F): | 1.380 g/cm ³ |

Solubility in / miscibility with

| | |
|-------------------|------------|
| water: | Insoluble. |
| Solvent content: | |
| Organic solvents: | 0.0 % |
| Solids content: | 94.5 % |

5.13.10 Stability and reactivity

Thermal decomposition / conditions to be avoided

No decomposition if used according to specifications.

Dangerous reactions

No dangerous reactions known.

Dangerous products of decomposition

Hydrogen chloride (HCl)

Toxic pyrolysis products.

5.13.11 Toxicological information

Acute toxicity

LD/LC50 values that are relevant for classification

| | | | |
|---|------|-------------------|--|
| 117-81-7 bis(2-ethylhexyl) phthalate | | | |
| Oral | LD50 | 30600 mg/kg (rat) | |
| Dermal | LD50 | 25000 mg/kg (rbt) | |

Primary irritant effect

On the skin: No irritant effect.

On the eye: No irritating effect.

Sensitization: No sensitizing effects known.

Additional toxicological information

The product is not subject to classification according to internally approved calculation methods for preparations.

When used and handled according to specifications, the product does not have any harmful effects according to our experience and the information provided to us.

5.13.12 Ecological information

General notes

Generally not hazardous to water

5.13.13 Disposal considerations

Product

Recommendation

Smaller quantities can be disposed of with household waste.
Can be disposed of under observance of the technical instructions after consultation with the local authorities and waste disposers.
Use one of the following waste key numbers.

Uncleaned packagings

Recommendation: Disposal must be according to official regulations.

5.13.14 Transport information

DOT regulations:

Hazard class: -

Land transport ADR/RID (cross-border):

ADR/RID class: -

Maritime transport IMDG:

IMDG Class: -

Marine pollutant: No

Air transport ICAO-TI and IATA-DGR:

ICAO/IATA Class: -

Transport/additional information:

Not hazardous according to the above specifications.

5.13.15 Regulations

Sara

Section 355 (extremely hazardous substances):

None of the constituents are listed.

Section 313 (Specific toxic chemical listings):

117-81-7 bis(2-ethylhexyl) phthalate

TSCA (Toxic Substances Control Act):

9010-98-4 Polychloropren CR

117-81-7 bis(2-ethylhexyl) phthalate

1309-48-4 magnesium oxide

1314-13-2 zinc oxide

97-39-2 1,3-di-o-tolylguanidine

101-67-7 bis(4-octylphenyl)amine

97-74-5 tetramethylthiuram monosulphide

Proposition 65

Chemicals known to cause cancer:

117-81-7 bis(2-ethylhexyl) phthalate

Chemicals known to cause reproductive toxicity:

None of the constituents are listed.

Carcinogenicity categories

EPA (Environmental Protection Agency)

117-81-7 bis(2-ethylhexyl) phthalate B2

1314-13-2 zinc oxide D

IARC (International Agency for Research on Cancer)

117-81-7 bis(2-ethylhexyl) phthalate 2B

NTP (National Toxicology Program)

117-81-7 bis(2-ethylhexyl) phthalate R

TLV (Threshold Limit Value established by ACGIH)

117-81-7 bis(2-ethylhexyl) phthalate A3

MAK (German Maximum Workplace Concentration)

None of constituents are listed.

NIOSH-Ca (National Institute for Occupational Safety and Health)

117-81-7 bis(2-ethylhexyl) phthalate

OSHA-Ca (Occupational Safety & Health Administration)

None of the constituents are listed.

Product-related hazard information

Observe the general safety regulations when handling chemicals.

The product has been classified in accordance with EU directives / national laws respectively.

In the version marketed, it presents no risk to the environment or to health.

Following directive 67 / 548 EC, annex VI, point 9.3 it is not necessary to be labelled.

Hazard symbols**U****National regulations****Technical instructions (air)**

| Class | Share in % |
|-------|------------|
| I | 0.4 |
| NK | 5.5 |

Water hazard class: Generally not hazardous to water.

Other regulations, limitations and prohibitive regulations

Subject to the regulations for N-Nitrosamines.

5.13.16 Other information

This information is based on our present knowledge. However, this shall not constitute a guarantee for any specific product features and shall not establish a legally valid contractual relationship.

Department issuing MSDS: Conseo GmbH Abteilung Umweltschutz

Contact: Hr. Dr. Kräbig / Hr. Dr. Laugwitz

6. Approvals

6.1 American Bureau of Shipping (ABS)

Certificate Number: 03-HS369456-3-PDA
29/APR/2015



Confirmation of Product Type Approval

Please refer to the "Service Restrictions" shown below to determine if Unit Certification is required for this product.

This certificate reflects the information on the product in the ABS Records as of the date and time the certificate is printed.

Pursuant to the Rules of the American Bureau of Shipping (ABS), the manufacturer of the below listed product held a valid Manufacturing Assessment (MA) with expiration date of 30/AUG/2016. The continued validity of the Manufacturing Assessment is dependent on completion of satisfactory audits as required by the ABS Rules.

And; a Product Design Assessment (PDA) valid until 11/SEP/2016 subject to continued compliance with the Rules or standards used in the evaluation of the product.

The above entitle the product to be called Product Type Approved.

The Product Design Assessment is valid for products intended for use on ABS classed vessels, MODUs or facilities which are in existence or under contract for construction on the date of the ABS Rules used to evaluate the Product.

ABS makes no representations regarding Type Approval of the Product for use on vessels, MODUs or facilities built after the date of the ABS Rules used for this evaluation.

Due to wide variety of specifications used in the products ABS has evaluated for Type Approval, it is part of our contract that; whether the standard is an ABS Rule or a non-ABS Rule, the Client has full responsibility for continued compliance with the standard.

Product Name: Fastening System

Model Name(s): Stainless powder-actuated Hilti X-BT threaded fasteners

Presented to:
HILTI AKTIENGESELLSCHAFT
FELDKIRCHERSTR. 100,
Liechtenstein

Intended Service: For fastening of fastened materials to base materials of carbon steel or stainless steel in the ship and shipbuilding environment and in off-shore structures.

Description: Fasteners Models: X-BT Models (M6 & W6, M8, M10, & W10), Composite Fasteners: X-FCM-R & X-FCM-M Fasteners: X-BT M6-24-6 SN-12-R, X-BT W6-24-6 SN-12-R, X-BT M8-15-6-R, X-BT M10-24-6-R, X-BT W10-24-6-R, X-BT M8-15-6 SN12-R, X-BT M10-24-6 SN12-R, & X-BT W10-24-6 SN12-R), Drilling Tool: XBT 4000-A & TX-BT 4/7 drills, Fastening Tool: DX 351-BT & DX 351-BTG Corrosion resistant steel threaded studs and accessories whereby fastening are made by using powder actuated tools to drive the fasteners into their final positions through a pre-drilled hole and without having to penetrate the base materials, in a process of pressing and fusing. Composite fasteners are either made from stainless material (X-FCM-R) or from duplex coated carbon steel (X-FCM-M)

Tier: 3

Ratings: 1. Refer to "Hilti X-BT Threaded Fastener Specification" for the recommended maximum loading in tension, shear, moment and torque, in association with the 'Conditions for recommended loads' specified therein. 2. Service Temperature: - 40 Celsius.

Service Restrictions: Unit Certification is not required for this product. If the manufacturer or purchaser request an ABS Certificate for compliance with a specification or standard, the specification or standard, including inspection standards and tolerances, must be clearly defined. 1) The Hilti X-BT fastenings are to be used for fastening various

04/29/2015 2:10:22 AM

Copyright 2001 American Bureau of Shipping. All rights reserved.

Page 1 of 3

Certificate Number: 03-HS369456-3-PDA

Comments:

materials to base metals of carbon/ stainless steel in ship and off-shore structures, i.a.w. the "Hilti X-BT Threaded Fastener Specification". 2) To ensure that proper anchoring/fastening mechanisms take place, i.e. pressing and fusing, the following fastening tools as recommended by the manufacturer shall be used: Drill bit: TX-BT 4/7, Fastening Tool: DX 351-BT & DX 351-BTG, Power Load 6.8/11M Brown. 3) Minimum base metal strengths are to be as follows: a) Carbon Steel: Ult. Tensile Strength (fu) = 360 N/mm2 (52 ksi) b) Stainless Steel: Ult. Tensile Strength (fu) = 360 N/mm2 (52 ksi) 4) The fasteners are to be installed using installation procedures recommended by the manufacturer. 5) In general, type approved X-BT fasteners are not to be used for the following locations: a) On bulkheads/decks with a thickness less than 8 mm b) Watertight boundaries c) For attachment of structural fire protection insulation 6) When type approved X-BT fasteners are to be used on structural members that are sensitive to stress patterns or variations and in areas where notch toughness is of paramount importance, the fatigue design is to be reviewed by ABS for acceptance and fracture toughness testing of materials is to be carried out in accordance with ABS Rules: 2-1-1/23 7) Type approved X-BT fasteners, if installed in fire rated divisions, shall be installed without the washer

Duplicate PDA resides with Precistec S.R.O. - KOPRIVNICE. In general, the Hilti X-BT fasteners may be used to fasten materials in areas where welding or drilling for bolting is permissible. It is recommended that fasteners be installed no closer than 6 mm from the edge of a flange or cutout and no closer than 15 mm between fasteners. The following additional guidance is provided for applications on ship structures: a) Acceptable applications: i) The securing of grating panels ii) The securing of checker plate iii) The securing of electrical cable trays iv) The securing of electrical cable clips v) The securing of joiner bulkhead tracks to plating in deck modules vi) The securing of light duty fixtures and light hangers vii) Securing of items 7a (i-vi) above and similar items in A-class boundaries viii) Use as grounding and bonding equipment b) Acceptable locations: i) On platform decks ii) On non-tight bulkheads iii) On lower decks iv) On transverse side frames v) In superstructures and deckhouse bulkheads vi) On Topside Deck members and plating vii) On Deck Modules viii) On members and plating in non-tight bulkheads and flats of hulls ix) On members in longitudinal and traverse frames of hulls c) Applications or locations where special care is recommended (see d below): i) In members with significant thermal stresses ii) In highly stressed portions of members iii) In members subject to high, cyclic loads iv) Hangers for pipe systems with high thermal stresses v) Hangers for sprinkler systems d) The Hilti X-BT fasteners may be used for the applications where special care is recommended by following the manufacturer's recommendation. Duplicate PDA resides with Precistec s.r.o - CZECH REPUBLIC. ABS approvals are general based on the product test reports furnished by recognized institutions and laboratories which may reflect specific local conditions. If any application is in a jurisdiction where the fasteners are subject to the approval process or specific guidelines are to be followed, the approved technical data or design guidelines take precedence over technical data presented herein.

Notes / Documentation:

Supporting Documentations: X-BT M6-24-6 SN12-R, item #: 432266; X-BT W6-24-6 SN12-R, item #: 432267; X-BT M8-15-6 SN12-R, item #: 377074; X-BT M10-24-6 SN12-R, item #: 377078; X-BT W10-24-6 SN12-R, item #: 377076; X-BT M8-15-6-R, item #: 377073; X-BT M10-24-6-R, item #: 377077; X-BT W10-24-6-R, item #: 377075.

Term of Validity:

This Product Design Assessment (PDA) Certificate 03-HS369456-3-PDA, dated 12/Sep/2011 remains valid until 11/Sep/2016 or until the Rules or specifications used in the assessment are revised (whichever occurs first). This PDA is intended for a product to be installed on an ABS classed vessel, MODU or facility which is in existence or under contract for construction on the date of the ABS Rules or specifications used to evaluate the Product. Use of the Product on an ABS classed vessel, MODU or facility which is contracted after the validity date of the ABS Rules and specifications used to evaluate the Product, will require re-evaluation of the PDA. Use of the Product for non ABS classed vessels, MODUs or facilities is to be to an agreement between the manufacturer and intended client.

ABS Rules:

2011 Steel Vessels Rules 1-1-4/7.7, 1-1-Appendix 3, 2008 MODU Rules 3-2-2/11; 4-3-3/5.9

National Standards:

1998 IMO Fire Test Procedures Code

International Standards:

04/29/2015 2:10:22 AM

Copyright 2001 American Bureau of Shipping. All rights reserved.

Page 2 of 3

Certificate Number: 03-HS369456-3-PDA

Government Authority:

EUMED:
Others: Manufacturer's Standards

| Model Certificate | Model Certificate No | Issue Date | Expiry Date |
|-------------------|----------------------|-------------|-------------|
| PDA | 03-HS369456-3-PDA | 12/SEP/2011 | 11/SEP/2016 |

ABS Programs

ABS has used due diligence in the preparation of this certificate and it represents the information on the product in the ABS Records as of the date and time the certificate was printed. Type Approval requires Drawing Assessment, Prototype Testing and assessment of the manufacturer's quality assurance and quality control arrangements. Limited circumstances may allow only Prototype Testing to satisfy Type Approval. The approvals of Drawings and Products remain valid as long as the ABS Rule, to which they were assessed, remains valid. ABS cautions manufacturers to review and maintain compliance with all other specifications to which the product may have been assessed. Further, unless it is specifically indicated in the description of the product; Type Approval does not necessarily waive witnessed inspection or survey procedures (where otherwise required) for products to be used in a vessel, MODU or facility intended to be ABS classed or that is presently in class with ABS. Questions regarding the validity of ABS Rules or the need for supplemental testing or inspection of such products should, in all cases, be addressed to ABS.

6.2 Lloyd's Register



Type Approval Certificate Extension

This is to certify that Certificate No. 03/00070(E1) for the undemoted products is extended and renumbered as shown.

This certificate is issued to:

| | |
|----------------------------|--|
| PRODUCER | Hilti Corporation |
| PLACE OF PRODUCTION | FL-9494 Schaan Principality of Liechtenstein |
| DESCRIPTION | Hilti X-BT direct mechanical fastening system, comprising Hilti fastening tool, drill bit and power loads. |
| TYPE | X-BT stainless steel threaded studs: Threaded stud connections: X-BT M6-24-6, SN12-R; X-BT W6-24-6, SN12-R; X-BT M8-15-6-R; X-BT M10-24-6-R; X-BT W10-24-6-R; X-BT M8-15-6 SN12-R; X-BT M10 24-6 SN12-R; X-BT W10-24-6 SN12-R; Composite fasteners: X-FCM-R |
| APPLICATION | For use in fastening to steel in marine, offshore and industrial environments. |
| SPECIFIED STANDARDS | Hilti X-BT Threaded Fastener Specification; Hilti Direct Fastening technology manual, Product Information. |

| | |
|------------------------|--------------|
| Certificate No. | 03/00070(E2) |
| Issue Date | 29 May 2013 |
| Expiry Date | 8 June 2018 |
| Sheet | 1 of 2 |

Lloyd's Register EMEA
71 Fenchurch Street, London EC3M 4BS

P. F. Moysey
London Design Support Office
Lloyd's Register EMEA

Lloyd's Register EMEA
is a subsidiary of Lloyd's Register Group

Lloyd's Register Group Limited, its affiliates and subsidiaries and their respective officers, employees or agents are, individually and collectively, referred to in this clause as the 'Lloyd's Register'. Lloyd's Register assumes no responsibility and shall not be liable to any person for any loss, damage or expense caused by reliance on the information or advice in this document or howsoever provided, unless that person has signed a contract with the relevant Lloyd's Register entity for the provision of this information or advice and in that case any responsibility or liability is exclusively on the terms and conditions set out in that contract.

LLOYD'S REGISTER GROUP PAPER 03/2003



OTHER CONDITIONS

1. This Type Approval certificate is to be read in conjunction with LR Technical Report no. 2003/CSG/TI/6331.
2. The minimum strength of the base material must be as stated in the Hilti X-BT Threaded Fastener Specification.
3. The end user must ensure that the base and fastened materials possess adequate corrosion resistance for the environments in which they are to be used.
4. For use on LR Classed ships, the locations and systems for which they are to be used are to be subject to a ship specific agreement.
5. Fatigue classification in accordance with EN 1993-1-9:2005 - Eurocode 3: Design of steel structures, is equivalent to category 90 m=3, and category 100 m=5,

"This Certificate is not valid for equipment, the design, ratings or operating parameters of which have been varied from the specimen tested. The manufacturer should notify Lloyd's Register EMEA of any modification or changes to the equipment in order to obtain a valid certificate."

The attached Design Appraisal Document No. 03/00070(E2) and its supplementary Type Approval Terms and Conditions form part of this Certificate.

All other details remain as the previous Certificate No. 03/00070(E1) to which this extension should be attached.

Certificate No. 03/00070(E2)
 Issue Date 29 May 2013
 Expiry Date 8 June 2018
 Sheet 2 of 2

Lloyd's Register EMEA
 71 Fenchurch Street, London EC3M 4BS

P. F. Moysey
 London Design Support Office
 Lloyd's Register EMEA

Lloyd's Register EMEA
 is a subsidiary of Lloyd's Register Group

Lloyd's Register Group Limited, its affiliates and subsidiaries and their respective officers, employees or agents are, individually and collectively, referred to in this clause as the 'Lloyd's Register'. Lloyd's Register assumes no responsibility and shall not be liable to any person for any loss, damage or expense caused by reliance on the information or advice in this document or howsoever provided, unless that person has signed a contract with the relevant Lloyd's Register entity for the provision of this information or advice and in that case any responsibility or liability is exclusively on the terms and conditions set out in that contract.



Lloyd's Register EMEA (London Office)
 LONDON DESIGN SUPPORT OFFICE
 71 Fenchurch Street, London, EC3M 4BS
 Telephone 020 7709 9166 Fax 020 7488 4796
 Email tad@lr.org

| |
|---------------------------------|
| Page 1 of 1 |
| Document number 03/00070(E2) |
| Issue number 1 |

DESIGN APPRAISAL DOCUMENT

| | |
|---------------------|--|
| Date 29 May 2013 | Quote this reference on all future communications LDSO/TA/W02745832/PFM/WP6969400 |
|---------------------|--|

LLOYD'S REGISTER TYPE APPROVAL SYSTEM, 2002.
 Issued to: HILTI CORPORATION
 for: X-BT DIRECT MECHANICAL FASTENING SYSTEM
 TYPE APPROVAL CERTIFICATE No. 03/00070(E2)

The undernoted documents have been reviewed for compliance with the requirements of the Lloyd's Register Type Approval System, 2002 and this Design Appraisal Document forms part of the Certificate.

APPROVAL DOCUMENTATION

| | |
|--|-------------|
| Request form | 06-Jun-2011 |
| Hilti Direct Fastening Technology Manual, ref. 387113 | Nov-2009 |
| Hilti X-BT Treaded Fastener Specification | Dec-2010 |
| Hilti X-BT Type Approvals Evaluation Report, ref. XE-10-90 | 11-May-2011 |
| Test reports as listed in above referenced evaluation report | |
| LR Dortmund visit report, ref. DTM 1383829 | 26-Apr-2013 |

Supplementary Type Approval Terms and Conditions

Type Approval certifies that a representative sample of the product(s) referred to herein has/have been found to meet the applicable design criteria for the use specified herein. It does not mean or imply approval for any other use, nor approval of any product(s) designed or manufactured otherwise than in strict conformity with the said representative sample.

Type Approval is based on the understanding that the manufacturer's recommendations and instructions and any relevant requirements of the Rules and Regulations are complied with.

Type Approval does not eliminate the need for normal inspection and survey procedures required by the Rules and Regulations.

Lloyd's Register EMEA reserves the right to cancel or withdraw this Type Approval Certificate in accordance with the Lloyd's Register Type Approval System Procedure.

P. F. Moysey
 Type Approval
 London Design Support Office
 Lloyd's Register EMEA/London Office
 Tel: +44 (0) 20 7423 1847

Lloyd's Register Group Limited, its affiliates and subsidiaries and their respective officers, employees or agents are, individually and collectively, referred to in this clause as the 'Lloyd's Register'. Lloyd's Register assumes no responsibility and shall not be liable to any person for any loss, damage or expense caused by reliance on the information or advice in this document or howsoever provided, unless that person has signed a contract with the relevant Lloyd's Register entity for the provision of this information or advice and in that case any responsibility or liability is exclusively on the terms and conditions set out in that contract.

6.3 Germanischer Lloyd (GL)

Approval Certificate



This is to certify, that the undernoted products have been approved in accordance with the relevant requirements of the GL Approval System.

Certificate No. 12 272 - 10 HH

Company Hilti Aktiengesellschaft

PO Box 333
9494 Schaan, LIECHTENSTEIN

Product MECHANICAL FASTENING SYSTEMS

Type HILTI X-BT STAINLESS STEEL THREADED FASTENERS

Technical Data / Application DESCRIPTION / TECHNICAL DATA
Hilti X-BT mechanical fastening system, comprising fastening and drilling tools and stainless steel threaded studs and accessories whereby fastening are made by using powder actuated tools to drive the fasteners into their final positions into a pre-drilled hole and without having to penetrate the base materials, in a process of pressing and fusing.

X-BT FASTENING SYSTEM:
Stainless steel threaded studs: X-BT M6-24-6 SN 12-R X-BT W6-24-6 SN 12-R
X-BT M8-15-6-R X-BT M8-15-6 SN 12-R
X-BT M10-24-6-R X-BT M10-24-6 SN 12-R
X-BT W10-24-6-R X-BT W10-24-6 SN 12-R
Composite fasteners: X-FCM-R, X-FCM-M
Drilling tool: XBT 4000-A drill, TX-BT 4/7 step drill bits
Fastening tools: DX 351 BTG for M8-types, DX 351 BT for M6/W6 and M10/W10-types
Cartridge: 6.8/11M brown "High Precision"

Approval Standard • Test processes in accordance with international recognized standards
• EN 1993-1-9: Eurocode 3: Design of Steel Structures – Part 1.9: Fatigue

Documents • Hilti X-BT Threaded Fastener Specification dated 2010/12, Supplement 2011/11
• Hilti Direct Fastening Technology Manual
• Test report Ermüdungsklassifikation gemäß EC 3 no. SO-ES 2011.101
• GL Approval Ref.-No. 11-069328, 12-004312

Remarks • RANGE OF APPLICATION/ FATIGUE DESIGN/ LIMITATION refer to page 2 and 3

Valid until 2015-11-15

File No. XI.B.09

Germanischer Lloyd

Hamburg, 2012-01-12

Hanspeter Raschle *Sven Dudszus*

Hanspeter Raschle

Sven Dudszus

Page 1 of 3

Approval Certificate



Certificate No. 12 272 - 10 HH

RANGE OF APPLICATION to CARBON/ STAINLESS STEEL BASE MATERIAL

The above mentioned products may be used for fastening various materials to base metals of carbon / stainless steel in ship structures and steel towers for wind turbines as follows:

- metal and fiberglass gratings to steel
- cable, conduit and tubing connectors to steel
- trays, channels and struts to steel for cable, conduit and tubing runs
- instrumentation, junction boxes, lighting
- pipe hangers
- signage
- door frames
- mounting cabinets, securing furniture, utensils, etc.
- grounding and bonding equipment

The fasteners may also be used for applications other than those listed above, subject to special consideration either by the local GL Surveyor or Germanischer Lloyd Head Office.

The minimum base material strengths are to be at least 360 [N/mm²]. In general the installation of the fasteners may be carried out in areas where welding or drilling for bolting is permissible. Fasteners are not be installed closer than 6 [mm] from the edge of a flange or cutout and closer than 15 [mm] between fasteners.

FATIGUE DESIGN to CARBON STEEL BASE MATERIAL

The X-BT fasteners are allowed to be used on structural members made from carbon steel that require fatigue verification. Fatigue verification of structural members in ship structures has to be made with the corresponding GL Rules for Classification and Construction and is subject to special consideration of Germanischer Lloyd Head Office.

Fatigue verification of steel towers for wind turbines are to be made in compliance with Eurocode 3 (EN 1993-1-9: Eurocode 3: Design of Steel Structures – Part 1.9: Fatigue). For fatigue verification of normal stresses the detail category 90 according to Fig. 7.1 of EN-1993-1-9 applies.

Description of constructional detail:
Structural steel base material with Hilti X-BT powder-actuated fastener driven in pre-drilled hole.
Imperfect fastener installations as pulled-out fasteners or pre-drilled holes without fasteners are covered.

Requirements/ Limitations:

The nominal stress range [N/mm²] is to be calculated by the gross cross-section fulfilling the requirements of the nominal stress approach.

Plate thickness: 8 [mm] ≤ t ≤ 60 [mm]
Minimum edge distance: 15 [mm]

Structural steel grades: S235 up to S460 according to EN 10025-2, EN 10025-3, EN 10025-4 and EN 10225

Germanischer Lloyd

Hamburg, 2012-01-12

Hanspeter Raschle *Sven Dudszus*

Hanspeter Raschle

Sven Dudszus

Page 2 of 3

6.4 Det Norske Veritas (DNV)

Approval Certificate

Certificate No. 12 272 - 10 HH

RANGE OF APPLICATION to CAST IRON BASE MATERIAL

The X-BT fasteners may also be used for fastening various materials to spheroid graphite cast iron components (e.g. components in the nacelle of towers for wind turbines) as follows:

- cable, conduit and tubing connections
- trays, channels and struts for cable, conduit and tubing runs
- instrumentation, junction boxes, lighting
- T-bars for cable and conduit connections
- pipe hangers
- signage

The fasteners may also be used for applications other than those listed above, subject to special consideration either by the local GL Surveyor or Germanischer Lloyd Head Office.

The recommended working loads as given in the X-BT Thread Fastener Specification (Supplement 2011/11) cover the effect of dynamic loading on the fasteners.

Cast iron specification:
EN-GJS-400 to EN-GJS-600 according to EN 1563

Requirements/ Limitations

Material thickness: $t \geq 20$ [mm]
Minimum edge distance: 6 [mm]
Minimum fastener spacing: 15 [mm]

LIMITATION

The X-BT fasteners are not to be used for the following locations:

- for attachment of structural fire protection insulation
- on bulkheads and decks with a thickness less than 8 [mm]
- on the shell plating, sea chests and collision bulkheads

The selection of the HILTI X-BT Fastening System for the corresponding application and the proper assembly are to be in accordance with the instructions of the manufacturer and the current Rules of Germanischer Lloyd as applicable.

Germanischer Lloyd

Hamburg, 2012-01-12

Hanspeter Raschle

Hanspeter Raschle

Sven Dudszus

Sven Dudszus

Page 3 of 3

DET NORSKE VERITAS

TYPE APPROVAL CERTIFICATE

CERTIFICATE NO. **S-6751**

This is to certify that the
Structural Connecting Elements

with type designation(s)
X-BT M6-24-6 SN12-R, X-BT W6-24-6 SN12-R, X-BT M8-15-6-R, X-BT M10-24-6-R, X-BT W10-24-6-R, X-BT M8-15-6 SN12-R, X-BT M10-24-6 SN12-R, X-BT W10-24-6 SN12-R, Grating Fastener X-FCM-R, Grating Fastener X-FCM-M

Manufactured by
Hilti Aktiengesellschaft
Schaan, Liechtenstein

is found to comply with
Det Norske Veritas' Rules for Classification of Ships and Mobile Offshore Units

Application
Fastening applications in shipbuilding, offshore structures and wind power plants. Typical examples are fastening of grating, fire protection, cable trays and pipe hangers.

Høvik, 2011-10-26
for Det Norske Veritas AS

Morten Bentzon

Morten Bentzon
Head of Section

DNV local office:
Essen

This Certificate is valid until
2015-12-31

Eilert Palm Vesterkjær

Eilert Palm Vesterkjær
Surveyor

This Certificate is subject to terms and conditions overleaf. Any significant change in design or construction may render this Certificate invalid. The validity date relates to the Type Approval Certificate and not to the approval of equipment/systems installed. If any person suffers loss or damage which is proved to have been caused by any negligent act or omission of Det Norske Veritas, then Det Norske Veritas shall pay compensation to such person for the proved direct loss or damage. However, the compensation shall not exceed an amount equal to ten times the fee charged for the service in question, provided that the maximum compensation shall never exceed USD 2 million. In this provision "Det Norske Veritas" shall mean the Foundation Det Norske Veritas as well as all its subsidiaries, directors, officers, employees, agents and any other acting on behalf of Det Norske Veritas.

DET NORSKE VERITAS AS, Veritasveien 1, NO-1322 Høvik, Norway, Tel.: +47 67 57 99 00, Fax: +47 67 57 99 11, Org.No. NO 945 748 931 MVA www.dnv.com
Form No.: TA 1411a Issue: October 2009 Page 1 of 3



Certificate No.: S-6751
File No.: 686.49
Job Id.: 262.1-007246-2

Product description

Powder actuated fastener with blunt tip with designation X-BT-R and grating fastening system X-FCM.

| Description | Type designation |
|---|----------------------|
| Threaded fastener | X-BT M8-15-6-R |
| Threaded fastener | X-BT M10-24-6-R |
| Threaded fastener | X-BT W10-24-6-R |
| Threaded fastener with sealing washer | X-BT M6-24-6 SN12-R |
| Threaded fastener with sealing washer | X-BT W6-24-6 SN12-R |
| Threaded fastener with sealing washer | X-BT M8-15-6 SN12-R |
| Threaded fastener with sealing washer | X-BT M10-24-6 SN12-R |
| Threaded fastener with sealing washer | X-BT W10-24-6 SN12-R |
| Grating Fastener, stainless steel | X-FCM-R 25/30 |
| Grating Fastener, stainless steel | X-FCM-R 1¼ - 1½ |
| Grating Fastener, stainless steel | X-FCM-R 35/40 |
| Grating Fastener, stainless steel | X-FCM-R 45/50 |
| Grating Fastener, carbon steel, duplex coated | X-FCM-M 25/30 |
| Grating Fastener, carbon steel, duplex coated | X-FCM-M 1¼ - 1½ |
| Grating Fastener, carbon steel, duplex coated | X-FCM-M 35/40 |
| Grating Fastener, carbon steel, duplex coated | X-FCM-M 45/50 |
| Hilti fastening tool | DX 351 BT |
| Hilti fastening tool | DX 351 BTG |
| Hilti drill bit | TX-BT 4/7 |
| Hilti Powder Loads for X-BT fasteners | 6.8/11M Brown |

Materials

Material in shank is high strength austenitic or ferritic-austenitic stainless steel. The threaded sleeve and the sealing washer are made from standard type 316/316L austenitic stainless steel.

| Description | Standard / Property requirement |
|--|---|
| Fastener shank | CR-500. Ultimate tensile, Rm > 1850 MPa, X2CrNiMoN22-5-3 (1.4462), X1NiCrMoCuN25-20-7 (1.4529) |
| Fastener threaded sleeve and SN12-R washer | Stainless steel X2CrNiMo17-12-2 (1.4404), X5CrNiMo17-12-2 (1.4401). |
| Fastener sealing washer | Black elastomer |
| Grating disk X-FCM-R | Disc: Stainless steel X2CrNiMo18-14-3, X2CrNiMo17-12-2 Threaded stem: Stainless steel X2CrNiMo17-13-2, X5CrNiMo17-12-2, X6CrNiMoTi17-12-2 |
| Grating disk X-FCM-M | Disc: Cold rolled carbon steel DC04 to EN 10130 Threaded stem: Bright (free cutting) steel 11SMnPb30+C to EN 10277. Disk and stem coated with duplex. |

Application/Limitation

Minimum base material thickness: 8 mm

Maximum base material thickness: no limit for X-BT using pre-drilled hole

Minimum yield strength of base material: 235 MPa

Design loads are given in the Hilti X-BT Threaded Fastener Specification, for two base material strengths; yield of 235 MPa and yield of 355 MPa. For the grating discs, different design loads are given for gratings with rectangular openings and square openings. Load ratings have been evaluated to meet the safety level requirement of DNV-OS-C101 and DNV-OS-C201.

For fatigue assessment of base material, the fatigue curve C2 in DNV-RP-C203 shall be used.

Installation of X-BT fasteners shall be performed according to procedures in the Hilti X-BT Threaded Fastener, Specification. Pre-drilled hole shall be made with the TX-BT 4/7 step shank drill bit to ensure correct dimensions of hole. The minimum edge distance is 6 mm. The maximum tightening torque of grating disc or a nut fitted to the threaded fastener is 8 Nm.

DET NORSKE VERITAS AS, Veritasveien 1, NO-1322 Høvik, Norway, Tel.: +47 67 57 99 00, Fax: +47 67 57 99 11, Org.No. NO 945 748 931 MVA www.dnv.com
Form No.: TA 1411a Issue: October 2009 Page 2 of 3



Certificate No.: S-6751
File No.: 686.49
Job Id.: 262.1-007246-2

Type Approval documentation

| Document title | Document number / Issue |
|--|---|
| Hilti X-BT Type Approvals: Evaluation report on complementary fastener specifications, new models, use as grounding device and fatigue classification | XE_10_90, May 11 th 2011 |
| HILTI. Hilti X-BT threaded fastener Specification | Edition 12/2010 |
| HILTI. X-FCM Grating Fastening System, Data sheets* | 11/2009 |
| Staatlich Autorisierte Bautechnische Versuchsanstalt. Test report about X-FCM-R and X-FCM grating discs loading capacity under pure tension and shear. | 269/95 |
| HILTI. Evaluation report on 5S-fastenings | XE_02_36, July 4 th 2002 |
| HILTI. Experimental investigations on the effect of Hilti 5S-fasteners on the fatigue strength of structural steel. | XE_02_08, June 18 th 2002 |
| HILTI. Investigations on the effect of dynamic base metal stresses (vibrations) on the pullout strength of Hilti 5S-fasteners. | XE_02_09, June 19 th 2002 |
| HILTI. Investigations on the effect of base metal tensile stresses on the pullout strength of Hilti 5S-fasteners. | XE_02_10, June 20 th 2002 |
| HILTI. Complementary evaluation report on X-BT-fastenings. | XE_03_01, January 14 th 2003 |

*from Hilti Direct Fastening Technology Manual

Tests carried out

Documentation of tests performed forming the basis for this type examination are referenced in the table above.

Marking of product

Marking shall consist of manufacturer's name or identification together with a type designation. The use of the DNV logo in relation to marketing and labelling of goods is not allowed without a written acceptance from DNV.

Certificate retention survey

For retention of the Type Examination, a DNV Surveyor shall perform a survey every second year and before the expire date of this certificate to verify that the conditions of the type examination are complied with.

END OF CERTIFICATE

DET NORSKE VERITAS AS, Veritasveien 1, NO-1322 Høvik, Norway, Tel.: +47 67 57 99 00, Fax: +47 67 57 99 11, Org.No. NO 945 748 931 MVA www.dnv.com
Form No.: TA 1411a Issue: October 2009 Page 3 of 3

6.5 Russian Maritime Register

| | | |
|---|---|--|
| РОССИЙСКИЙ МОРСКОЙ РЕГИСТР СУДОХОДСТВА RUSSIAN MARITIME REGISTER OF SHIPPING | | 6.8.3 |
|  | | |
| СВИДЕТЕЛЬСТВО О ТИПОВОМ ОДОБРЕНИИ TYPE APPROVAL CERTIFICATE | | |
| Изготовитель Manufacturer | Hilti Aktiengesellschaft | |
| Адрес Address | Feldkircherstrasse 100, 9494 Schaan, Liechtenstein. | |
| Изделие* Product* | Система механического крепления типа HILTI X-BT. Mechanical fastening system of HILTI X-BT type. | |
| Код номенклатуры Code of nomenclature | 11210000 | |
| <p>На основании освидетельствования и проведенных испытаний удостоверяется, что вышеупомянутое(ые) изделие(я) удовлетворяет(ют) требованиям Российского морского регистра судоходства. This is to certify that on the basis of the survey and tests carried out the above mentioned item(s) complies(ly) with the requirements of Russian Maritime Register of Shipping.</p> <p>Часть XI "Электрическое оборудование" Правил классификации и постройки морских судов 2013 г. издания. Part XI "Electrical equipment" of Rules for the classification and construction of sea-going ships, Edition 2013.</p> | | |
| <p>Настоящее Свидетельство о типовом одобрении действительно до 05.06.2018 This Type Approval Certificate is valid until</p> <p>Настоящее Свидетельство о типовом одобрении теряет силу в случаях, установленных в Правилах технического наблюдения за постройкой судов и изготовлением материалов и изделий для судов. This Type Approval Certificate becomes invalid in cases stipulated in Rules for the Technical Supervision during Construction of Ships and Manufacture of Shipboard Materials and Products.</p> | | |
| Дата выдачи Date of issue | 05.06.2013 | № 13.40019.250 |
| Российский морской регистр судоходства Russian Maritime Register of Shipping |  | В.В. Морозов / V. Morozov (фамилия, инициалы name |
| *Дополнительную информацию смотри на обороте. Additional information see overleaf. | | |

| | | |
|---|---------|--------------|
| <p>Технические данные Technical data Hilti X-BT система механического крепления, состоящая из инструментов для сверления и установки резьбовых шпилек из нержавеющей стали и принадлежностей при помощи порохового монтажного пистолета в предварительно сделанное отверстие посредством запрессовки с фрикционным свариванием шпильки и базового материала.</p> <p>Шпильки из нержавеющей стали типа: X-BT M6-24-6 SN12-R, X-BT W6-24-6 SN12-R, X-BT M8-15-6-R, X-BT M10-24-6-R, X-BT W10-24-6-R, X-BT M8-15-6 SN12-R, X-BT M10-24-6 SN12-R, X-BT W10-24-6 SN12-R</p> <p>Композитный крепеж для крепления решеток: X-FCM-R, Grating Fastener X-FCM-M Инструмент для сверления: Дрель XBT 4000-A, Сверло TX-BT 4/7 Пороховой монтажный пистолет: DX 351 BT / DX 351-BTG Патроны в ленте: 6.8/11 M brown</p> <p>Hilti X-BT mechanical fastening system, comprising fastening and drilling tools and stainless steel threaded studs and accessories whereby fastening are made by using powder actuated tools to drive the fasteners into their final positions into a pre-drilled hole in a process of pressing and fusing.</p> <p>Stainless steel threaded studs: X-BT M6-24-6 SN12-R, X-BT W6-24-6 SN12-R, X-BT M8-15-6-R, X-BT M10-24-6-R, X-BT W10-24-6-R, X-BT M8-15-6 SN12-R, X-BT M10-24-6 SN12-R</p> <p>Composite fasteners for gratings: X-FCM-R, Grating Fastener X-FCM-M Drilling tool: XBT 4000-A drill, TX-BT 4/7 step drill bit Fastening tool: DX 351 BT / DX 351-BTG Cartridge: 6.8/11 M brown</p> <p>Техническая документация и дата ее одобрения Российским морским регистром судоходства Technical documentation and the date of its approval by Russian Maritime Register of Shipping Техническая документация одобрена письмом No. 250-315-2-106273 от 05.06.2013 г.</p> <p>Technical documentation is approved by the letter No. 250-315-2-106273 of 05.06.2013.</p> <p>Образец изделия испытан под техническим наблюдением Российского морского регистра судоходства. Product's specimen has been tested under the technical supervision of Russian Maritime Register of Shipping.</p> <p>Акт № 13.40019.250 от 05.06.2013 Report No. of</p> <p>Область применения и ограничения Application and limitations Для механического крепления различных материалов и устройств к конструкциям корпуса морских судов. Минимальная толщина базового материала 8 мм. Минимальный предел текучести базового материала 235 МПа. Монтаж крепежа X-BT должен быть выполнен в соответствии с требованиями документа "Hilti X-BT Threaded Fastener Specification". Крепеж X-BT не должен использоваться для монтажа конструктивной противопожарной защиты, для крепления к наружной обшивке корпуса судна, таранным переборкам и в кингстонных ящиках. Выбор системы крепления HILTI X-BT для соответствующего применения и надлежащего монтажа должен осуществляться в соответствии с инструкциями изготовителя, изложенными в документе "Hilti X-BT Threaded Fastener Specification" и применимыми требованиями действующих Правил Российского морского регистра судоходства.</p> <p>For mechanical fastening of various materials and units to hull structures of sea-going ships. Minimum base material thickness 8 mm. Minimum yield strength of base material 235 MPa. Installation of X-BT fasteners shall be performed according to procedures in the Hilti X-BT Threaded Fastener Specification. The X-BT fasteners are not to be used for attachment of structural fire protection insulation, on the shell plating, collision bulkheads and sea chests. The selection of the HILTI X-BT Fastening System for the corresponding application and the proper assembly are to be in accordance with the instructions of the manufacturer in the Hilti X-BT Threaded Fastener Specification and the current Rules of Russian Maritime Register of Shipping as applicable.</p> <p>Вид документа, выдаваемого на изделие Type of document issued for product Изделия должны поставляться с копией настоящего Свидетельства о типовом одобрении. The products shall be delivered with the copy of this Type Approval Certificates.</p> | 02/2012 | 13.40019.250 |
|---|---------|--------------|

6.6 Bureau Veritas (BV)

Page 1 / 4



**BUREAU
VERITAS**

Certificate number: 23498/A1 BV
File number: ACM 139/1905/1
Product code: 0226H

This certificate is not valid when presented without the full attached schedule composed of 7 sections

www.veristar.com

TYPE APPROVAL CERTIFICATE

This certificate is issued to

Hilti Aktiengesellschaft
SCHAAN - LIECHTENSTEIN

for the type of product

MECHANICAL FASTENING SYSTEM
HILTI X-BT MECHANICAL FASTENING SYSTEM

Requirements:
BUREAU VERITAS Rules for the Classification of Steel Ships
BUREAU VERITAS Rules for the Classification of Offshore Units
BUREAU VERITAS Rules for the Classification of Naval Ships
BUREAU VERITAS Rules for the Classification of Yachts

This certificate is issued to attest that BUREAU VERITAS did undertake the relevant approval procedures for the product identified above which was found to comply with the relevant requirements mentioned above.

This certificate will expire on: 19 Apr 2016

For BUREAU VERITAS,
At BV HAMBURG, on 28 Mar 2012,
Adama Diene



This certificate remains valid until the date stated above, unless cancelled or revoked, provided the conditions indicated in the subsequent page(s) are complied with and the product remains satisfactory in service. This certificate will not be valid if the applicant makes any changes or modifications to the approved product, which have not been notified to, and agreed in writing with BUREAU VERITAS. Should the specified regulations or standards be amended during the validity of this certificate, the product(s) is/are to be re-approved prior to it/they being placed on board vessels to which the amended regulations or standards apply. This certificate is issued within the scope of the General Conditions of BUREAU VERITAS Marine Division available on the Internet site www.veristar.com. Any Person not a party to the contract pursuant to which this document is delivered may not assert a claim against BUREAU VERITAS for any liability arising out of errors or omissions which may be contained in said document, or for errors of judgement, fault or negligence committed by personnel of the Society or of its Agents in establishment or issuance of this document, and in connection with any activities for which it may provide.

BV Mod. Ad.E 530 May 2009 This certificate consists of 4 page(s)

Page 2 / 4

Certificate number: 23498/A1 BV

THE SCHEDULE OF APPROVAL

1. PRODUCT DESCRIPTION :

Hilti X-BT mechanical fastening system, comprising Hilti fastening tool, power load, drill bit, stainless steel threaded studs and accessories, whereby fastenings are made by using powder-actuated tools to drive the fasteners into their final positions into a pre-drilled hole and without having to penetrate the base materials in a process of pressing and fusing.

Identification of Components:

| Component Name | Designation |
|-----------------------|--|
| X-BT M6-24-6 SN12-R | Stainless steel threaded stud M6 with sealing washer |
| X-BT W6-24-6 SN12-R | Stainless steel threaded stud W6 with sealing washer |
| X-BT M8-15-6-R | Stainless steel threaded stud M8 |
| X-BT M8-15-6 SN12-R | Stainless steel threaded stud M8 with sealing washer |
| X-BT M10-24-6-R | Stainless steel threaded stud M10 |
| X-BT M10-24-6 SN12-R | Stainless steel threaded stud M10 with sealing washer |
| X-BT W10-24-6-R | Stainless steel threaded stud 3/8" |
| X-BT W10-24-6 SN12-R | Stainless steel threaded stud 3/8" with sealing washer |
| X-FCM-R 25/30 | Stainless steel grating fastener |
| X-FCM-R 1 1/4 - 1 1/2 | Stainless steel grating fastener |
| X-FCM-R 35/40 | Stainless steel grating fastener |
| X-FCM-R 45/50 | Stainless steel grating fastener |
| X-FCM-M 25/30 | Grating fastener, carbon steel, duplex coated |
| X-FCM-M 1 1/4 - 1 1/2 | Grating fastener, carbon steel, duplex coated |
| X-FCM-M 35/40 | Grating fastener, carbon steel, duplex coated |
| X-FCM-M 45/50 | Grating fastener, carbon steel, duplex coated |
| TX-BT 4/7 | 4/7 step drill bit |
| DX 351 BTG | Fastening tool for M8-types |
| DX 351 BT | Fastening tool for M6/W6 and M10/W10-types |
| 6.8/11M brown | Cartridge |

2. DOCUMENTS AND DRAWINGS :

| Designation | Revision / Date |
|---|-----------------------|
| Hilti X-BT Threaded Fastener Specification | Edition December 2010 |
| Hilti Direct Fastening Technology Manual | Edition November 2009 |
| Technical documentation on Hilti X-BT direct fastening system | Edition May 2011 |

3. TEST REPORTS :

According to the following tests:

- Test Report No. 257/09 at Bautechnische Versuchsanstalt HTL Rankweil/AUSTRIA on 27.09.2010
- Investigation Report 901 8035 000/Bf at MPA University of Stuttgart/GERMANY on 02.11.2009
- Test Report No. 095/10 at Bautechnische Versuchsanstalt HTL Rankweil/AUSTRIA on 11.06.2010
- Report No. 09-1K-0208.32V3_e at Electrosuisse, Fehraltorf/SWITZERLAND on 06.04.2011
- Test Report No. CF-791 at Dehn+Söhne GmbH+Co. KG, Neumarkt/GERMANY on 22.03.2006
- Report No. 2010-57X at University of Stuttgart/GERMANY on 28.12.2010
- Test Report No. TWU FSRL-13/09 at Hilti Corporation, Schaan/LIECHTENSTEIN on 20.04.2010
- Test Report No. 453'150/1e at EMPA, Dübendorf/SWITZERLAND on 09.03.2010
- Test Report No. 453'150/2e at EMPA, Dübendorf/SWITZERLAND on 11.05.2010
- Test Report No. 453'150/3e at EMPA, Dübendorf/SWITZERLAND on 10.06.2010
- Test Report No. 455'377/e at EMPA, Dübendorf/SWITZERLAND on 08.12.2010

BV Mod. Ad.E 530 May 2009 This certificate consists of 4 page(s)

4. APPLICATION / LIMITATION :

- 4.1 The mechanical fastening system is intended for fastening applications in shipbuilding and offshore structures as far as the BUREAU VERITAS Rules are complied with:
- Metal and fiberglass grating
 - Cable, conduit and tubing connectors
 - Trays, channels and struts for cable, conduit and tubing runs
 - Instrumentation, Junction Boxes, Lighting
 - Pipe hangers
 - Signage
 - Door frames
 - Mounting cabinets, securing furniture, utensils, etc.
 - Earthing (Grounding), bonding to coated steel and/or high strength steel.
- 4.2 The minimum thickness of the base material is not to be less than 8 mm, through penetration of base steel is not allowed.
- 4.3 The maximum thickness of the fastened material is for the X-BT M8 not to be more than 7.0 mm, for the X-BT M6 / X-BT W6 not to be more than 14.0 mm and for the X-BT M10 / X-BT W10 not to be more than 15.0 mm.
- 4.4 The minimum distance to the edge of a flange or cutout is not to be less than 6 mm and the minimum spacing between fasteners is not to be less than 15 mm.
- 4.5 The minimum yield strength of the base steel is not to be less than 235 N/mm² and the minimum tensile strength is not to be less than 340 N/mm².
- 4.6 The mechanical fastening system may be used in areas where drilling for bolting is permissible.
- 4.7 The maximum tightening torque of grating disc or nut fitted to the threaded fastener is not to be more than 8 Nm.
- 4.8 The fasteners are not to be used on structural members requiring fatigue verification.
- 4.9 The manufacturer's assembly instructions and recommendations are to be complied with.

5. PRODUCTION SURVEY REQUIREMENTS :

- 5.1 The mechanical fastening systems are to be manufactured, examined and tested by the manufacturer in accordance with the approved type described in this certificate and in accordance with BUREAU VERITAS Rules stated on the front page of this certificate.
- 5.2 The production sites are to be recognized by BUREAU VERITAS as per NR 320 for HBV products. To this end, the manufacturer has to make the necessary arrangements for a Society's Surveyor to perform visits and product audits at the production sites.
- 5.3 Hilti Aktiengesellschaft has declared to BUREAU VERITAS that the fasteners X-BT are manufactured at the following production sites:
- Hilti Plant 1**
Feldkircherstrasse 100
PO Box 333
FL-9494 Schaan
Liechtenstein
 and
Precistec s.r.o.
Pod Stadionem 7
74221 Koprivnice
Czech Republic

The accessory, the grating fastener X-FCM-R and X-FCM-M, are manufactured at the following production site:
WP-Wörgartner Produktions GmbH
Bahnhofstraße 21
A-6372 Oberndorf
Austria

6. MARKING OF PRODUCT :

The mechanical fastening system should be clearly identified with:

- Manufacturer's name or logo
- Type designation

7. OTHERS :

- 7.1 The mechanical fastening systems will be delivered with the relevant documentation / user's guide.
- 7.2 This approval is given on the understanding that the Society reserves the right to require check tests to be carried out on the units at any time and that Hilti Aktiengesellschaft, Schaan – Liechtenstein and Precistec s.r.o., Koprivnice – Czech Republic, will accept full responsibility for informing shipbuilders, ship owners or their subcontractors of the proper methods of use and general maintenance of the units and the conditions of this approval.
- 7.3 This Certificate supersedes the Type Approval Certificate N° 23498/A0 BV issued on 19 Apr 2011 by the Society.

*** END OF CERTIFICATE ***

6.7 ICC-ES



Most Widely Accepted and Trusted

ICC-ES Evaluation Report

ESR-2347*

Reissued December 2013

This report is subject to renewal December 1, 2015.

www.icc-es.org | (800) 423-6587 | (562) 699-0543

A Subsidiary of the International Code Council®

DIVISION: 05 00 00—METALS
Section: 05 05 23—Metal Fastenings

REPORT HOLDER:

HILTI, INC.
5400 SOUTH 122ND EAST AVENUE
TULSA, OKLAHOMA 74146
(800) 879-8000
www.us.hilti.com
HNATechnicalServices@hilti.com

EVALUATION SUBJECT:

HILTI LOW-VELOCITY POWDER-ACTUATED DRIVEN
THREADED STUDS FOR ATTACHMENT TO STEEL

1.0 EVALUATION SCOPE

Compliance with the following codes:

- 2012 *International Building Code*® (IBC)
- 2012 *International Residential Code*® (IRC)
- 2009, 2006 and 2003 *International Building Code*® (IBC)*
- 2009, 2006 and 2003 *International Residential Code*® (IRC)*

*Codes indicated with an asterisk are addressed in Section 8.0.

Property evaluated:

Structural

2.0 USES

The Hilti Powder-Actuated Driven Threaded Studs are used as alternatives to the welds and bolts used to attach materials to structural steel, which are described in IBC Sections 2204.1 and 2204.2, respectively. The fasteners may be used for structures regulated under the IRC, when an engineered design is submitted in accordance with IRC Section R301.1.3.

3.0 DESCRIPTION

3.1 General:

Hilti low-velocity powder-actuated threaded studs are fasteners with male threads for attachment on one end and a pointed- or blunt-tip shank on the other end for embedment into the supporting steel. Both shank types may be supplied with a plastic washer for the carbon steel fasteners or a stainless steel washer for the stainless steel fasteners. The threaded studs with pointed-tip shanks are

driven directly into the steel. The threaded studs with blunt-tip shanks (X-BT type) must be driven into a predrilled pilot hole. The threaded studs are available with the thread designations and lengths and in the materials shown in Table 1. See Figures 1 and 2 for illustrations of pointed- and blunt-tip shank threaded studs.

3.2 Materials:

Carbon steel threaded studs are manufactured from hardened steel and are zinc-plated in accordance with ASTM B633 SC 1, Type III. Except for the M6 and W6 versions of the X-BT type fasteners, stainless steel threaded studs are composed of two main components, the threaded sleeve and the drive pin. The threaded sleeve and washer are manufactured from SAE 316 stainless steel. The drive pin is manufactured from a proprietary CrNiMo alloy complying with the requirements of SAE 316. In the case of the M6 and W6 X-BT type fasteners, they are manufactured as one piece from a proprietary CrNiMo alloy complying with the requirements of SAE 316 stainless steel.

3.3 Steel Substrates:

Structural steel must comply with the minimum strength requirements of ASTM A36, ASTM A572 Grade 50 or ASTM A992, and must have the minimum thicknesses, yield strength and tensile strength as shown in Tables 2 and 3.

4.0 DESIGN AND INSTALLATION

4.1 Design:

4.1.1 Allowable Loads: The most critical applied loads, excluding seismic load effects, resulting from the load combinations in IBC Section 1605.3.1 or 1605.3.2 must not exceed the allowable loads given in this section. For fasteners which are subjected to seismic loads, see Section 4.1.3 for additional requirements. The allowable shear and tension loads for the threaded studs installed in steel are found in Tables 2 and 3. The stress increases and load reductions described in IBC Section 1605.3 are not allowed for wind loads acting alone or when combined with gravity loads. No increase is allowed for vertical loads acting alone. Allowable loads apply to the connection of the stud to the base material only. Design of the connection of the attached material must comply with the applicable requirements of the IBC.

Allowable loads for fasteners subjected to combined shear and tension forces are determined by the following formula:

$$(p/P_s) + (v/V_s) \leq 1$$

*Revised July 2014

ICC-ES Evaluation Reports are not to be construed as representing aesthetics or any other attributes not specifically addressed, nor are they to be construed as an endorsement of the subject of the report or a recommendation for its use. There is no warranty by ICC Evaluation Service, LLC, express or implied, as to any finding or other matter in this report, or as to any product covered by the report.

Copyright © 2014



Page 1 of 5

ESR-2347 | Most Widely Accepted and Trusted

Page 2 of 5

where:

- p = Actual tension load, lbf (N).
- P_s = Allowable tension load, lbf (N).
- v = Actual shear load, lbf (N).
- V_s = Allowable shear load, lbf (N).

4.1.2 Wood to Steel Connections: Reference lateral design loads for fasteners determined in accordance with Part 11 of ANSI/AF&PA NDS are applicable to Hilti fasteners of equal or greater diameters. The wood element must be considered to be the side member. The fastener bending yield strength is allowed to be taken as the value noted in the NDS, based on the fastener diameter.

Hilti stainless steel threaded studs may be installed in contact with preservative-treated wood or fire-retardant-treated wood, as set forth in the applicable code. Carbon steel threaded studs may be used in contact with fire-retardant-treated wood in dry, interior locations only, as per IBC Section 2304.9.5.4 and per the manufacturer's recommendations. Use of carbon steel threaded studs in contact with preservative-treated wood and with fire-retardant-treated wood in exterior applications is outside the scope of this report.

4.1.3 Seismic Considerations: When the Hilti threaded studs are installed in steel and are subjected to seismic loads, the most critical load applied to each individual stud must be determined from the applicable equations in IBC Section 1605.3.1 or Section 1605.3.2, and must not exceed the allowable seismic load shown in Table 2 or 3, including the footnotes, as applicable. Recognition of the Hilti fasteners for use in the design of lateral force resisting systems, such as shear walls and diaphragms, is outside the scope of this report.

4.2 Installation:

4.2.1 General: The powder-actuated threaded studs must be installed in accordance with this report and the Hilti, Inc., published installation instructions. A copy of these instructions must be available on the jobsite at all times during installation. Installation is limited to dry, interior locations, except for stainless steel fasteners, which may be installed in exterior or damp environments.

Fastener placement requires the use of a Hilti low-velocity powder-actuated tool in accordance with Hilti, Inc. recommendations. Threaded studs must be installed with stud stand-off, h_{wts} , dimensions as defined in Figure 3 and Table 1. Minimum spacing between fasteners must be 1 inch (25.4 mm) and minimum edge distance must be 1/2 inch (12.7 mm). Installers must be certified by Hilti and have a current, Hilti-issued, operator's license.

4.2.2 X-BT Blunt-tip Threaded Studs: The X-BT blunt-tip threaded studs require a pilot hole predrilled to the required depth with a Hilti TX-BT 4/7 step shank drill bit, in accordance with the manufacturer's published installation instructions. Installation instructions for the X-BT threaded studs are illustrated in Figure 5.

5.0 CONDITIONS OF USE

The Hilti Low-Velocity Powder-Actuated Driven Threaded Studs described in this report comply with, or are suitable alternatives to what is specified in, those codes listed in Section 1.0 of this report, subject to the following conditions:

5.1 The fasteners are manufactured and identified in accordance with this report.

5.2 Fastener installation complies with this report and the Hilti, Inc. published instructions. In the event of conflict between this report and the Hilti, Inc., published instructions, this report governs.

5.3 Calculations demonstrating that the actual loads are less than the allowable loads described in Section 4.1 must be submitted to the code official for approval. The calculations must be prepared by a registered design professional where required by the statutes of the jurisdiction in which the project is constructed.

5.4 Refer to Section 4.1.3 for seismic considerations.

5.5 Stainless steel threaded studs may be installed in exterior, damp environments. Use of carbon steel threaded studs is limited to dry, interior locations, which include exterior walls which are protected by an exterior wall envelope.

5.6 Installation must comply with Section 4.1.2 regarding fasteners in contact with preservative-treated and fire-retardant-treated wood.

5.7 Installers must be certified by Hilti, Inc., and have a current, Hilti-issued, operator's license.

6.0 EVIDENCE SUBMITTED

Data in accordance with the ICC-ES Acceptance Criteria for Fasteners Power-driven into Concrete, Steel and Masonry Elements (AC70), dated June 2014, including seismic load test data in accordance with Annex A of AC70.

7.0 IDENTIFICATION

Each package of fasteners is labeled with the product designation, the manufacturer's name (Hilti), and the evaluation report number (ESR-2347). An "H", for Hilti, is marked on the head of each carbon steel threaded stud. An "HI" is marked on the head of each stainless steel threaded stud. These head markings are shown in Figure 4.

8.0 OTHER CODES

8.1 Evaluation Scope:

In addition to the 2012 IBC and 2012 IRC addressed in Sections 2.0 through 7.0, the products in this report were evaluated for compliance with the requirements of the following codes:

- 2009, 2006 and 2003 *International Building Code*® (2009, 2006 and 2003 IBC)
- 2009, 2006 and 2003 *International Residential Code*® (2009, 2006 and 2003 IRC)

8.2 Uses:

The Hilti Powder-Actuated Driven Threaded Studs are used as alternatives to the welds and bolts used to attach materials to structural steel, as described in 2009, 2006 and 2003 IBC Sections 2204.1 and 2204.2, respectively. The fasteners may be used for structures regulated under the IRC, when an engineered design is submitted in accordance with 2009, 2006 and 2003 IRC Section R301.1.3, as applicable.

8.3 Description:

See Section 3.0.

8.4 Design and Installation:

8.4.1 Design:

8.4.1.1 Allowable Loads: See Section 4.1.1.

8.4.1.2 Wood-to-Steel Connections: See Section 4.1.2, with the following modification:

- Under the 2009 IBC: See Section 4.1.2 regarding use in preservative-treated and fire-retardant-treated wood.
- Under the 2006 and 2003 IBC: Hilti stainless steel threaded studs may be installed in contact with preservative-treated or fire-retardant-treated wood, as set forth in the applicable code. Use of carbon steel threaded studs in contact with preservative-treated or fire-retardant-treated wood is outside the scope of this report.

8.4.1.3 Seismic Considerations: See Section 4.1.3.

8.4.2 Installation: See Section 4.2.

8.5 Conditions of Use:

See Section 5.0, and the following:

8.5.1 Refer to Section 8.4.1.2 regarding use in preservative-treated and fire-retardant-treated wood.

8.6 Evidence Submitted:

See Section 6.0.

8.7 Identification:

See Section 7.0.

TABLE 1—THREADED STUD DESCRIPTIONS

| PRODUCT DESIGNATION | THREAD DESIGNATION | SHANK DIAMETER in. (mm) | NOMINAL THREAD LENGTH in. (mm) | NOMINAL SHANK LENGTH in. (mm) | MATERIAL | THREADED STUD STAND-OFF, h_{NVS} ¹ in. (mm) |
|-----------------------------------|--------------------|-------------------------|--------------------------------|-------------------------------|-----------------|--|
| Pointed-Tip | | | | | | |
| X-EW6H-11-9 | UNC 1/4-inch | 0.145 (3.7) | 1/16 (11) | 3/8 (9) | Carbon steel | 3/8 - 1/2 (9.5-12.5) |
| X-EW6H-20-9 | UNC 1/4-inch | 0.145 (3.7) | 3/16 (20) | 3/8 (9) | Carbon steel | 23/32 - 27/32 (18.5-21.5) |
| X-EW6H-28-9 | UNC 1/4-inch | 0.145 (3.7) | 1/8 (28) | 3/8 (9) | Carbon steel | 11/16 - 13/16 (28.5-29.5) |
| X-EW6H-38-9 | UNC 1/4-inch | 0.145 (3.7) | 1/2 (38) | 3/8 (9) | Carbon steel | 11/16 - 13/16 (38.5-39.5) |
| X-EW10H-30-14 | UNC 3/8-inch | 0.205 (5.2) | 13/16 (30) | 9/16 (14) | Carbon steel | 13/16 - 15/16 (28.0-31.0) |
| X-CRM8-9-12 | Metric 8 mm | 0.157 (4.0) | 3/8 (9) | 1/2 (12) | Stainless steel | 7/16 - 19/32 (11.0-15.0) |
| X-CRM8-15-12 | Metric 8 mm | 0.157 (4.0) | 3/8 (15) | 1/2 (12) | Stainless steel | 3/8 - 23/32 (18.0-20.0) |
| Blunt-Tip | | | | | | |
| X-BT W6-24-6 SN12-R | UNC 1/4-inch | 0.177 (4.5) | 15/16 (24) | 1/4 (6) | Stainless steel | 1 - 1 1/16 (25.7-26.8) |
| X-BT M6-24-6 SN12-R | Metric 6 mm | 0.177 (4.5) | 15/16 (24) | 1/4 (6) | Stainless steel | 1 - 1 1/16 (25.7-26.8) |
| X-BT M8-15-6-R ² | Metric 8 mm | 0.177 (4.5) | 3/8 (15) | 1/4 (6) | Stainless steel | 3/8 - 11/16 (15.7-16.8) |
| X-BT M8-15-6 SN12-R ² | Metric 8 mm | 0.177 (4.5) | 3/8 (15) | 1/4 (6) | Stainless steel | 3/8 - 11/16 (15.7-16.8) |
| X-BT W10-24-6-R ² | UNC 3/8-inch | 0.177 (4.5) | 15/16 (24) | 1/4 (6) | Stainless steel | 1 - 1 1/16 (25.7-26.8) |
| X-BT W10-24-6 SN12-R ² | UNC 3/8-inch | 0.177 (4.5) | 15/16 (24) | 1/4 (6) | Stainless steel | 1 - 1 1/16 (25.7-26.8) |
| X-BT M10-24-6-R ² | Metric 10 mm | 0.177 (4.5) | 15/16 (24) | 1/4 (6) | Stainless steel | 1 - 1 1/16 (25.7-26.8) |
| X-BT M10-24-6 SN12-R ² | Metric 10 mm | 0.177 (4.5) | 15/16 (24) | 1/4 (6) | Stainless steel | 1 - 1 1/16 (25.7-26.8) |

For SI: 1 inch = 25.4 mm.

¹See Figure 3 for depiction of h_{NVS} .

²The suffix "Spec" may follow the M8, M10 and W10 designations, indicating the use of an alternate proprietary stainless steel specification.

TABLE 2—ALLOWABLE LOADS FOR POINTED-TIP THREADED STUDS DRIVEN INTO STEEL^{1,2,3} (lbf)

| Fastener | Shank Dia. (in.) | Steel Thickness (in.) | | | | | | | | | |
|----------|------------------|-----------------------|-------|---------|-------|---------|-------|---------|-------|---------|-------|
| | | 3/16 | | 1/4 | | 3/8 | | 1/2 | | ≥ 3/4 | |
| | | Tension | Shear | Tension | Shear | Tension | Shear | Tension | Shear | Tension | Shear |
| X-EW6H | 0.145 | 380 | 500 | 500 | 600 | 500 | 600 | 500 | 600 | - | - |
| X-EW10H | 0.205 | - | - | 970 | 1000 | 1100 | 1100 | 1100 | 1100 | 800 | 800 |
| X-CRM8 | 0.157 | - | - | 405 | 405 | 405 | 405 | 405 | 405 | - | - |

For SI: 1 inch = 25.4 mm, 1 lbf = 4.4 N, 1 psi = 6895 Pa.

Notes:

¹Tabulated allowable load values based upon embedment in steel such that threaded stud stand-off, h_{NVS} , complies with Table 1.

²All allowable load capacities above are based on base steel with a minimum yield strength (F_y) of 36 ksi and a minimum tensile strength (F_u) of 58 ksi.

³Allowable loads are applicable to static and seismic loads in accordance with Section 4.1.

TABLE 3—ALLOWABLE LOADS FOR BLUNT-TIP (X-BT) THREADED STUDS DRIVEN INTO STEEL ≥ 1/16 INCH THICK^{1,2,3}

| Fastener | Shank Dia. (in.) | Tension (lbf) | Shear (lbf) |
|--|------------------|------------------|------------------|
| X-BT M6, X-BT W6, X-BT M8, X-BT M10, or X-BT W10 | 0.177 | 405 ⁴ | 585 ⁵ |

For SI: 1 inch = 25.4 mm, 1 lbf = 4.4 N, 1 psi = 6895 Pa.

Notes:

¹Tabulated allowable load values based upon embedment in steel such that threaded stud stand-off, h_{NVS} , complies with Table 1.

²All allowable load capacities above apply to base steel with a minimum yield strength (F_y) of 36 ksi and a minimum tensile strength (F_u) of 58 ksi.

³Installation of fasteners must be in accordance with Section 4.2.2 and Figure 5 of this report.

⁴Tabulated allowable tension load is applicable to static and seismic loads in accordance with Section 4.1.

⁵Tabulated allowable shear load is applicable to static loads in accordance with Section 4.1. For seismic loads, multiply the tabulated shear load by 0.915 for the X-BT M6 and X-BT W6 fasteners or by 0.983 for the X-BT M8, X-BT M10 and X-BT W10 fasteners.

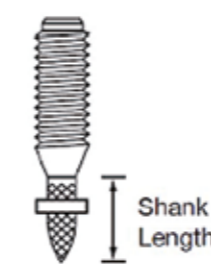

FIGURE 1—POINTED-TIP THREADED STUD

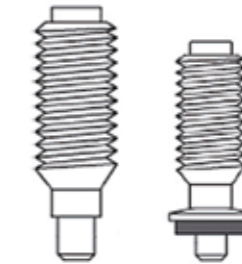

FIGURE 2—HILTI X-BT BLUNT-TIP THREADED STUD WITH AND WITHOUT SN12-R SEALING WASHER

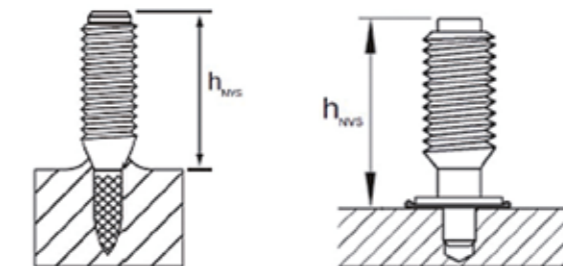

FIGURE 3—DEPICTION OF THREADED STUD STAND-OFF, h_{NVS} , FOR POINTED-TIP AND BLUNT-TIP THREADED STUDS



FIGURE 4—DEPICTION OF IDENTIFYING HEAD MARKINGS FOUND ON TOP OF THREADED STUDS: "H" FOUND ON CARBON STEEL STUDS AND "HI" FOUND ON STAINLESS STEEL STUDS



1. Mark location for each fastening
2. Pre-drill with TX-BT 4/7 step shank drill bit
3. Drive fastener into drilled hole only with DX351-BT/BTG tool and Hilti 6.8/11M High Precision brown cartridge. High Precision cartridge is a cartridge with a specific energy level and a narrow energy band.
4. Install material to be fastened, washer and nut
5. Tighten nuts using an electric screw driver with torque clutch or torque wrench.

Installation Details

Pre-drill until shoulder grinds a shiny ring (to assure proper drilling depth).



Before fastener installation:
The drilled hole must be clear of liquids and debris. Area around drilled hole must be free from liquids and debris.

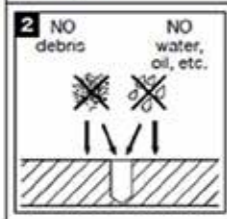

Adjust power on the **DX351-BT/BTG** so that the fastener stand-off, h_{MS} , is:

| Fastener | h_{MS} |
|-----------------|------------------------------|
| X-BT W6 and W10 | 1.012"-1.055" (25.7-26.8 mm) |
| X-BT M8 | 0.618"-0.661" (15.7-16.8 mm) |

Proper compression of the sealing washer must be achieved.

Power regulation guide to check fastener stand-off available from Hilti.

Tightening torque, $T_{req} = 6 \text{ ft-lb (8 Nm)}$

| Hilti Tool | Torque Setting ¹ |
|------------|-----------------------------|
| SFH 18-A | 9-10 |
| SF 18-A | 9-10 |
| SFH 144-A | 9-10 |
| SF 144-A | 9-10 |

¹ Tool torque settings are for guideline purposes. Tool wear and temperature as well as battery charge will influence torque characteristics.

FIGURE 5—INSTALLATION INSTRUCTIONS FOR HILTI X-BT THREADED STUDS



Most Widely Accepted and Trusted

ICC-ES Evaluation Report

ESR-2347 FBC Supplement*

Reissued December 2013

This report is subject to renewal December 1, 2015.

www.icc-es.org | (800) 423-6587 | (562) 699-0543 A Subsidiary of the International Code Council®

DIVISION: 05 00 00—METALS
Section: 05 05 23—Metal Fastenings

REPORT HOLDER:

HILTI, INC.
5400 SOUTH 122ND EAST AVENUE
TULSA, OKLAHOMA 74146
(800) 879-8000
www.us.hilti.com
HNATechnicalServices@hilti.com

EVALUATION SUBJECT:

HILTI LOW-VELOCITY POWDER-ACTUATED DRIVEN THREADED STUDS FOR ATTACHMENT TO STEEL

1.0 REPORT PURPOSE AND SCOPE

Purpose:

The purpose of this evaluation report is to indicate that the Hilti Low-Velocity Powder-Actuated Driven Threaded Studs for Attachment to Steel, recognized in ICC-ES master evaluation report ESR-2347, has also been evaluated for compliance with the codes noted below.

Applicable code editions:

- 2010 Florida Building Code—Building
- 2010 Florida Building Code—Residential

2.0 CONCLUSIONS

The Hilti Low-Velocity Powder-Actuated Driven Threaded Studs for Attachment to Steel, described in Sections 2.0 through 7.0 of the master report ESR-2347, comply with the 2010 Florida Building Code—Building and the 2010 Florida Building Code—Residential, provided the design and installation are in accordance with the 2009 International Building Code® (IBC) provisions noted in the master report, and the following conditions apply:

- Design wind loads must be based on Section 1609 of the 2010 Florida Building Code—Building or Section 301.2.1.1 of the 2010 Florida Building Code—Residential, as applicable.
- Load combinations must be in accordance with Section 1605.2 or Section 1605.3 of the 2010 Florida Building Code—Building, as applicable.
- Use of the Hilti Low-Velocity Powder-Actuated Driven Threaded Studs for Attachment to Steel has also been found to be in compliance with the High-Velocity Hurricane Zone provisions of the 2010 Florida Building Code—Building and the 2010 Florida Building Code—Residential under the following conditions:
 - Use of the Hilti Low-Velocity Powder-Actuated Driven Threaded Studs for Attachment to Steel as a means of attachment of wood blocking, as defined in Section 2330.1.1 of the 2010 Florida Building Code—Building, in a roof assembly in the High-Velocity Hurricane Zone, is prohibited.
 - Design wind loads must be based on Section 1620 of the 2010 Florida Building Code—Building.

For products falling under Florida Rule 9N-3, verification that the report holder's quality assurance program is audited by a quality assurance entity approved by the Florida Building Commission for the type of inspections being conducted is the responsibility of an approved validation entity (or the code official when the report holder does not possess an approval by the Commission).

This supplement expires concurrently with the master report reissued December 2013, revised July 2014.

*Revised July 2014

ICC-ES Evaluation Reports are not to be construed as representing aesthetics or any other attributes not specifically addressed, nor are they to be construed as an endorsement of the subject of the report or a recommendation for its use. There is no warranty by ICC Evaluation Service, LLC, express or implied, as to any finding or other matter in this report, or as to any product covered by the report.



Hilti. Outperform. Outlast.

Hilti Corporation | 9494 Schaan | Liechtenstein | P +423-234 2111 | F +423-234 2965 | www.hilti.com